



CM-1001  
June 1, 2021

# CM-420 Combustion Monitor Installation and Operation



**508A**  
**Enclosed Industrial  
Control Panel**

## DESCRIPTION

The CM-420 Combustion Monitor is designed to connect to the Fireeye NXCESO2 or FXCESO2 (with FXO2TRIM-1 interface) in situ oxygen probes. These probes utilize industrial sensors with integrated heater and pump controls. This allows these Fireeye oxygen probes to be used in applications without Fireeye efficiency controls.

The CM-420 provides power and communication to the oxygen probe through a four-wire cable connection. While the oxygen probe is designed to mount in the stack, the CM-420 is designed for remote mounting, typically on the side of the boiler or appliance. The CM-420 has UL508A listing for enclosed industrial control panels. The enclosure is IP65 (NEMA 4X) rated.

The CM-420 provides a 4-20mA output to represent the current O<sub>2</sub> reading from the oxygen probe. Two 4-20mA analog inputs are provided to allow connection to an inlet temperature sensor as well as an auxiliary sensor that can be configured to measure any other site need. Four programmable relay outputs are provided for alarm status that are configured by default to indicate O<sub>2</sub> low, low-low (manual reset), high and high-high (manual reset) conditions. There is also a dry contact input provided to initiate calibration for the oxygen probe when needed.

The CM-420 is configured using the 7" touchscreen. Communication is available to a PLC/SCADA/BMS using Modbus TCP/IP and/or Modbus RTU via RS-232, RS-422 or RS-485. All operating information including O<sub>2</sub> percent, stack temperature, inlet temperature and auxiliary input are provided, as well as the ability to initiate commands to the oxygen probe or directly control the relay outputs via Modbus. All communication parameters are configurable.

See Fireeye bulletin *NXCESO2-1001* or *FXCESO2-1001* for additional information on mounting and wiring of the oxygen probe. This bulletin only covers installation and operation of the CM-420 Combustion Monitor.

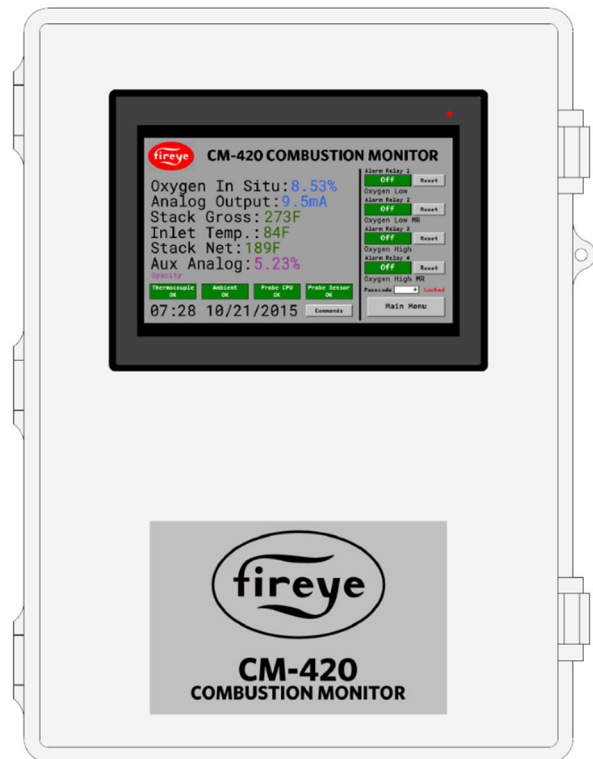

**WARNING: Do not connect or disconnect oxygen probe while energized as this can present an explosion hazard.**



---

## TABLE OF CONTENTS

DESCRIPTION.....	1
TECHNICAL DATA .....	3
ORDERING INFORMATION.....	4
SAFETY ADVICE .....	5
MOUNTING.....	5
Dimensional Diagram .....	6
WIRING .....	7
Terminals.....	8
Fuses.....	8
Wiring Diagram.....	9
Quick Disconnect Adapter.....	11
Wiring to NXCESO2.....	12
Wiring to FXCESO2 with FXO2TRIM-1 .....	13
Quick Disconnect Cord Sets .....	14
Quick Disconnect Field Wiring .....	15
INTERFACE .....	16
Navigation .....	16
Probe Commands .....	17
Main Menu.....	18
Information .....	19
Fault History .....	20
SETTINGS .....	21
General.....	21
Probe.....	22
Analog Inputs .....	24
Analog Output .....	25
Alarm Relays.....	26
Network .....	29
MODBUS.....	30
Modbus Connection .....	30
Modbus Mapping.....	31
CERTIFICATIONS .....	35
NOTICE.....	36
WARRANTIES .....	36



---

## TECHNICAL DATA

Screen type:	TFT, 4-wire analog resistive
Resolution:	800 x 480
Diagonal screen area:	177.8mm (7 in.)
Backlight:	LED rated at 20,000 hours at 25°C
Interface method to oxygen probe:	Modbus RTU via RS-485
Nominal voltage:	100VAC-240VAC (45Hz-65Hz)
Nominal power consumption:	124.3VA
Internal power supply maximum output:	60W (24VDC)
Relay output ratings:	230VAC/2A, pilot duty only
Analog input resolution:	16-bit
Analog output resolution:	12-bit
Operating temperature range:	0°C to 60°C (32°F to 140°F)
Operating humidity:	10% to 95%, non-condensing
Storage temperature range:	-20°C to 85°C (-4°F to 185°F)
Shock during operation:	25g acceleration for 11ms
Degree of protection:	IP65 (NEMA 4X), indoor use only (not UV stabilized)
Unit dimensions:	270mm x 370mm (10.64 in. x 14.59 in.)
Unit dimensions depth:	151mm (5.92 in.)
Weight:	4.76kg (10.5 lb.)



## ORDERING INFORMATION

Combustion Monitor		Bulletin
NXCM-420	Combustion monitor for use with Fireeye oxygen probe.	CM420-1001
NXCESO2 Oxygen Probe		Bulletin
NXCESO2-8	Standard O2 probe assembly, 216 mm (8.5 inch) insertion depth.	NXCESO2-1001
NXCESO2-16	Standard O2 probe assembly, 407 mm (16 inch) insertion depth.	
NXCESO2-8-KIT	Kit, NXCESO2-8 with FXIATS-140 and 35-381-2.	
NXCESO2-16-KIT	Kit, NXCESO2-16 with FXIATS-140 and 35-381-2.	
FXCESO2-8	High temperature O2 probe assembly, 215 mm (8 inch) insertion depth. Requires FXO2TRIM-1 control board.	FXCESO2-1001
FXCESO2-16	High temperature O2 probe assembly, 406 mm (16 inch) insertion depth. Requires FXO2TRIM-1 interface module.	
FXCESO2-30	High temperature O2 probe assembly, 757 mm (30 inch) insertion depth. Requires FXO2TRIM-1 interface module.	
FXO2TRIM-1	O2 probe interface module for FXCESO2 probes.	
35-381-2	O2 probe mounting flange.	133-750
Inlet Temperature Sensor		Bulletin
FXIATS-140	Ambient air temperature sensor, -40°C to 60°C (-40°F to 140°F), 4-20mA.	FXIATS-1
Connectors and Cable		Bulletin
129-192	Quick disconnect connector for field wiring, female (cable 59-565 recommended).	133-747
129-194	Quick disconnect connector with wire leads, male.	n/a
59-565-6	Quick disconnect cord set, 6 feet, PVC jacket, temperature rating -40°C to 105°C, meets NEMA 1,3,4,6P and IEC67.	133-748
59-565-40	Quick disconnect cord set, 6 feet, PVC jacket, temperature rating -40°C to 105°C, meets NEMA 1,3,4,6P and IEC67.	
59-565	Cable to connect CM-420 to NXCESO2 or FXO2TRIM-1, separate power and communication, sold by the foot.	n/a

---

## SAFETY ADVICE

The CM-420 Combustion Monitor only provides readings from the connected Fireeye oxygen probe. The CM-420 does not provide any control of the process. Use proper caution when applying any values read from the CM-420 to a combustion process including any necessary redundancy checks.

The programmable relay outputs are not safety rated and are designed to be used for status reporting only. Check the technical specifications for the rating of these relays.

## MOUNTING

The CM-420 enclosure is designed for mounting indoors as the ABS poly blend of the enclosure is not UV stabilized. The enclosure has four mounting bosses that are designed for connecting to the provided mounting clips using M5 x 0.8mm bolts. These mounting clips can be mounted in any orientation that works best.



*Mounting clip boss*



*Mounting clip fastened to boss*



## Dimensional Diagram

The following diagram shows the footprint with the mounting clips attached and oriented in an up/down arrangement.

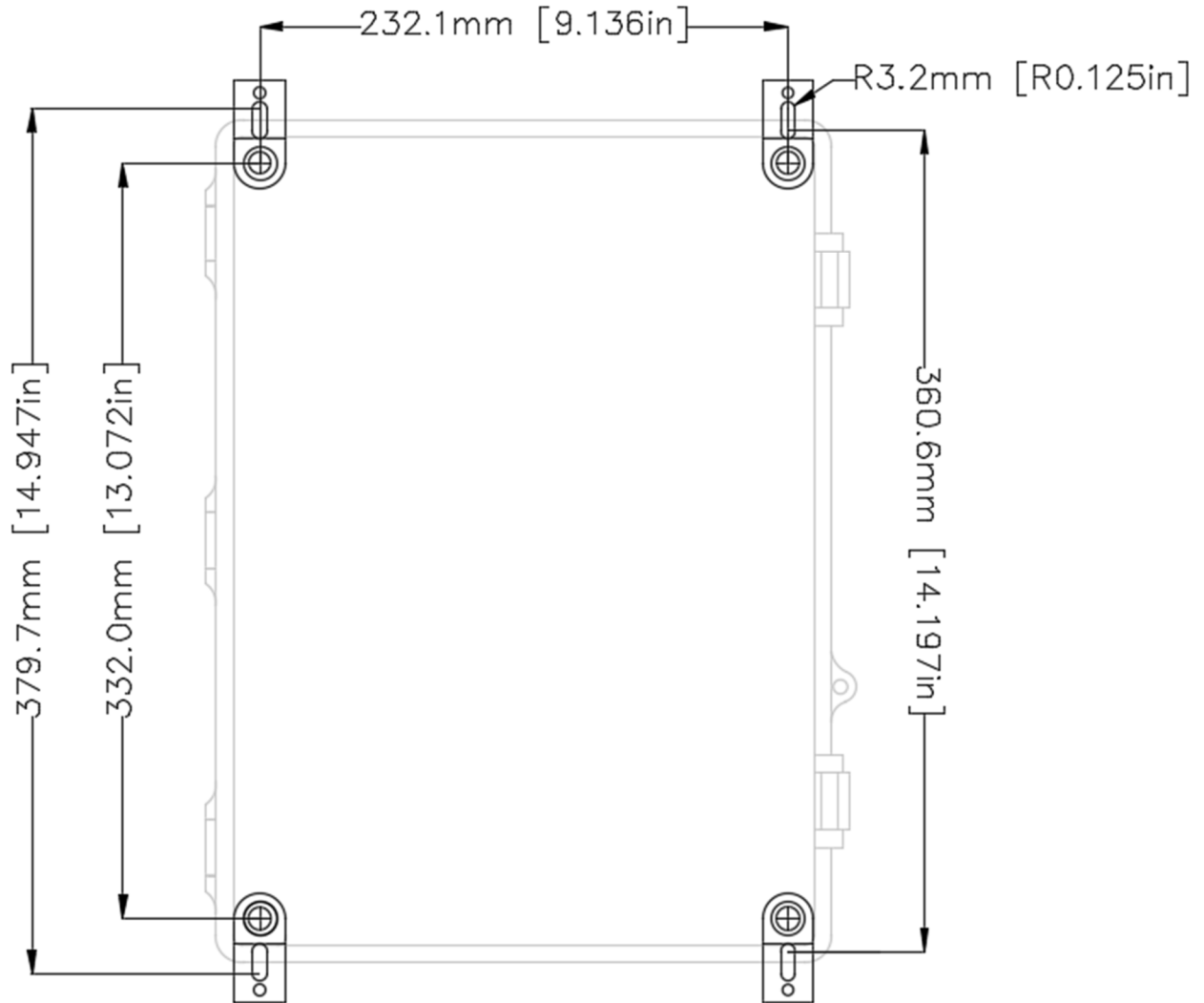



---

## WIRING

All conduit entry points should be drilled from the bottom of the enclosure. Ensure that no internal components can be damaged in the process. Also make sure that any fittings used will comply with the desired IP or NEMA rating as the IP65 (NEMA 4X) ratings only apply before any penetrations are made. The rating after penetrations depends on the rating of the connectors.

Be sure to connect the ground connection first to eliminate any ESD (electrostatic discharge) potential.



**WARNING: Do not penetrate the top of the CM-420 enclosure when wiring. Doing so may result in debris entering the internal devices.**

Five wires must be connected to power and communicate with the NXCESO2. A cord set (59-565) with all the necessary wiring is available.

Quick disconnecting cord sets are also available. Quick disconnect fittings are also available for field construction and installation. The 129-194 quick disconnect adapter can be fitted to the bottom of the CM-420 on the left side for direct connection to terminals P1, P2, P3 and P4. Another 129-194 can then be fitted to the NXCESO2. This allows use of a quick disconnect cord (such as the 59-565-40) directly from the CM-420 to the NXCESO2.

Eight wires must be connected between the FXCESO2 probe and the FXO2TRIM-1 interface. A cable set (59-612-33) with a six-conductor cable and two-conductor thermocouple wire is available. Five wires must be connected to power and communicate with the FXO2TRIM-1. A cord set (59-565) with all the necessary wiring is available. The 129-194 quick disconnect adapter can be fitted to the bottom of the CM-420 on the left side for direct connection to terminals P1, P2, P3 and P4. Another 129-194 can then be fitted to the FXO2TRIM-1. This allows use of a quick disconnect cord (such as the 59-565-40) directly from the CM-420 to the FXO2TRIM-1.



## Terminals

Terminal	Type	Description	Notes
P1	Power	24VDC+ to NXCESO2 probe or FXO2TRIM-1 interface	Via 59-565 cable RED wire
P2	Common	24VDC- to NXCESO2 probe or FXO2TRIM-1 interface	Via 59-565 cable BLACK wire
P3	Modbus	Modbus A to NXCESO2 probe or FXO2TRIM-1 interface	Via 59-565 cable ORANGE wire
P4	Modbus	Modbus B to NXCESO2 probe or FXO2TRIM-1 interface	Via 59-565 cable BROWN wire
G	Ground	Grounding to NXCESO2 probe or FXO2TRIM-1 interface	Via 59-565 cable bare wire
SP	Power	24VDC+ to sensors	Use for loop powered sensors
S1	Analog In	4-20mA signal from inlet sensor	Not isolated
S2	Analog In	4-20mA signal from auxiliary sensor	Not isolated
SC	Common	24VDC- from sensor	Use for self-powered sensors
G	Ground	Grounding for analog shielded cables	
PV	Analog Out	4-20mA signal representing oxygen percentage	Not isolated
PC	Common	Common signal for analog out	Connected to 24VDC-
DC	Power	Common for digital input	Connected to 24VDC+
D1	Digital In	Digital input to initiate calibration	Connect D1 to DC with button or relay (dry contact)
R1	Relay out	Programmable relay output alarm 1 Default = Oxygen < 2.0% (LOW)	230V/2A, pilot duty only
R2	Relay out	Programmable relay output alarm 2 Default = Oxygen < 1.0%, manual reset (LOW-LOW)	
R3	Relay out	Programmable relay output alarm 3 Default = Oxygen > 12.0% (HIGH)	
R4	Relay out	Programmable relay output alarm 4 Default = Oxygen > 13.0%, manual reset (HIGH-HIGH)	
RC	Common	Common for all relay outputs	
L1	Power In	Line voltage input 120VAC (50Hz/60Hz) Line voltage input 230VAC (50Hz/60Hz)	Input range 100VAC-240VAC nominal, 45Hz-65Hz
L2	Power In	Neutral input 120VAC (50Hz/60Hz) Line voltage input 230VAC (50Hz/60Hz)	
G	Ground	To earth ground	

## Fuses

There is one internal fuse that protects the 24VDC power supply. The fuse is marked FU5 and is a Bussmann FNQ-R-1 or equivalent.





## Wiring Diagram

The following is the as-built wiring diagram for the CM-420 (split to two pages):

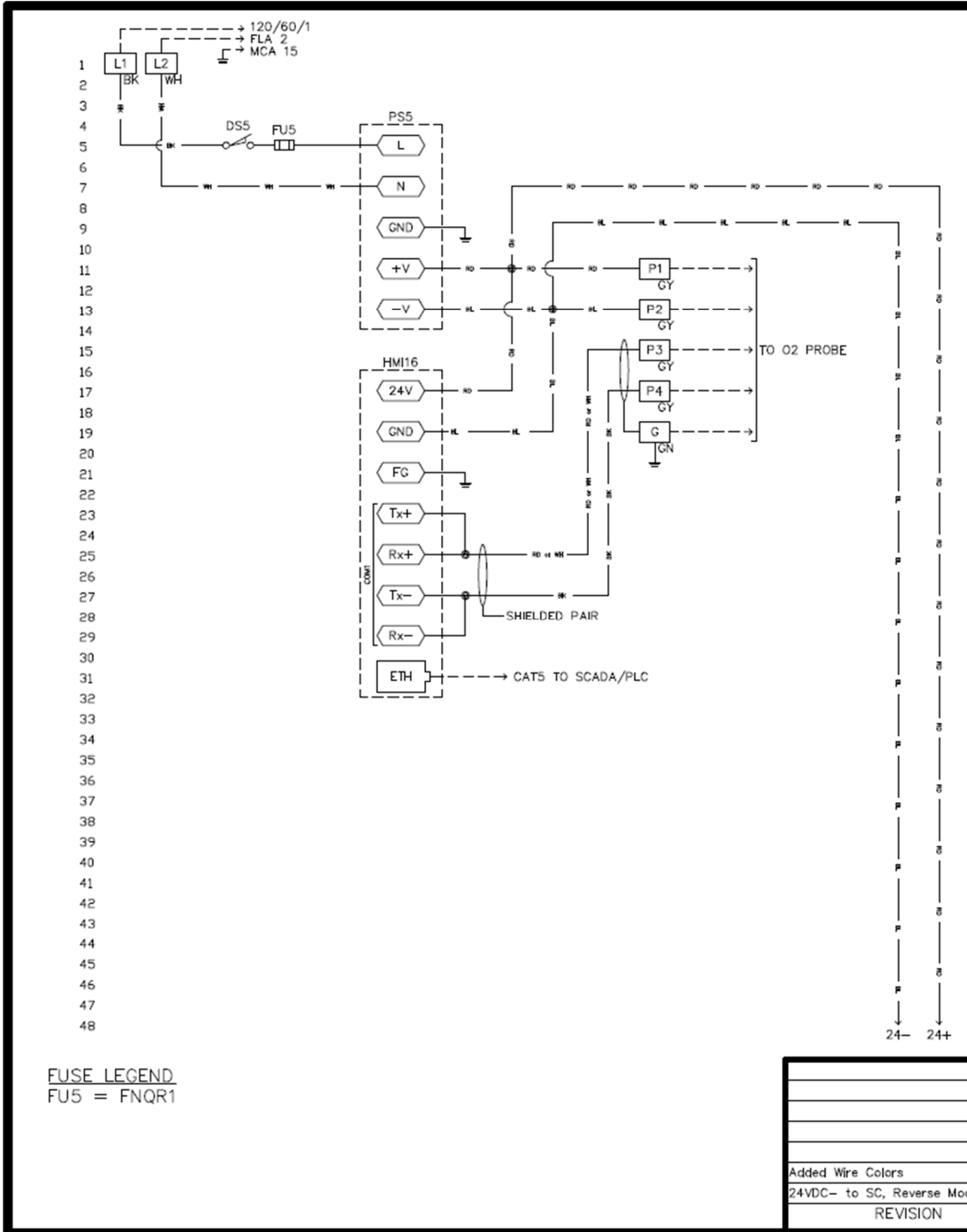

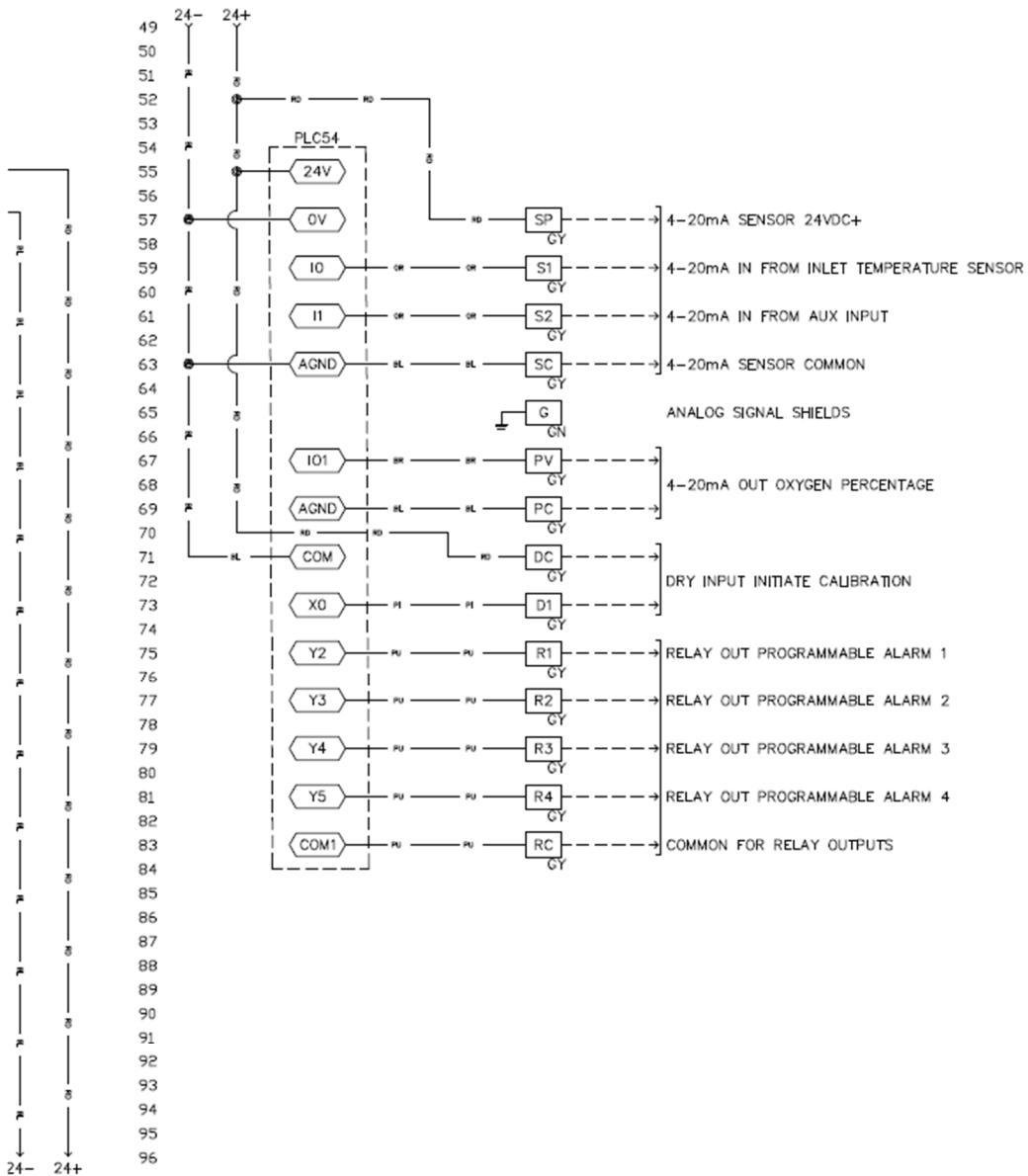

			DRAWN BY CZ	APPROVED BY RL
			DATE DRAWN 11/5/2020	
			DRAWING NUMBER CM-420	
ors	CAZ	12/31/2020	TITLE CM-420 PANEL UL508A	
Reverse Modbus	CAZ	12/18/2020		
REVISION	BY	DATE		





---

## Quick Disconnect Adapter

A quick disconnect adapter (Fireeye part 129-194) can be fitted to the bottom of the CM-420 enclosure. Place the fitting on the left side, below terminals P1, P2, P3 and P4.

A trade size  $\frac{1}{2}$ " hole (22mm or 0.875 in.) is required to mount the adapter. Using a regular  $\frac{1}{2}$ " NPT conduit locknut is sufficient for IP10 (NEMA 1) rating use. If the IP65 (NEMA 4X) rating should be maintained, first fit a  $\frac{1}{2}$ " NPT watertight conduit hub through the panel, then thread the quick disconnect adapter into that. The watertight conduit hub has a sealing gasket to maintain the NEMA rating.

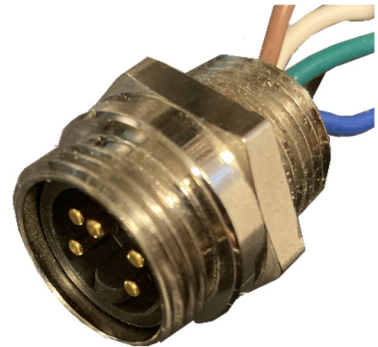

Use the following color scheme for wiring the adapter:

Color	Terminal	Description
White	P1	24VDC+
Blue	P2	24VDC-
Brown	P3	Modbus A
Black	P4	Modbus B
Green/yellow	G	Earth ground



## Wiring to NXCESO2

If desired, fit a quick disconnect adapter (Fireye part 129-194) to the NXCESO2. Access to the terminals is possible after loosening the screws and removing the cooling fan.

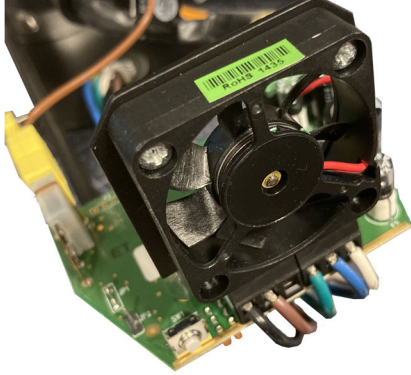

*Loosen screws and remove cooling fan to access terminals*

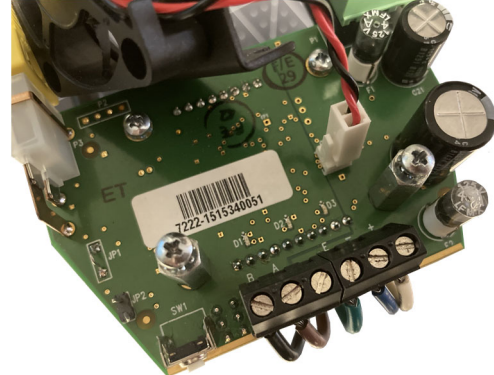

*Connect wiring to terminals (quick disconnect wiring is shown here)*

Use the following color scheme for wiring the quick disconnect adapter:

Color	Terminal	Description
White	+	24VDC+
Blue	-	24VDC-
Green/yellow	E	Earth ground
Brown	A	Modbus A
Black	B	Modbus B

For direct wiring, wire to the following chart (color coding for Fireye cable 59-565 is shown):

CM-420 Terminal	NXCESO2 Terminal	59-565 Color
P1	+	Red
P2	-	Black
G	E	Bare
P3	A	Orange
P4	B	Brown

## Wiring to FXCESO2 with FXO2TRIM-1

Wire the FXCESO2 oxygen probe to the FXO2TRIM-1 interface using the 59-612-33 cable. Wire the FXO2TRIM-1 using 59-565 cable.

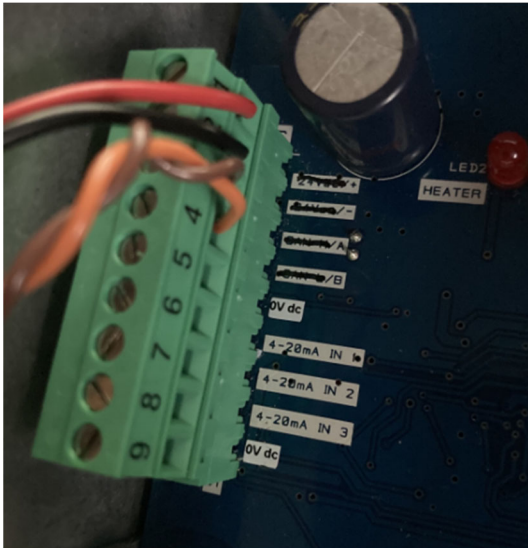

Remove cover from FXO2TRIM-1 to access terminals

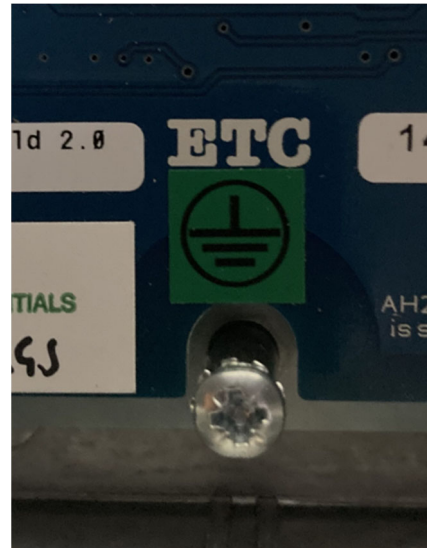

Grounding connection for FXO2TRIM-1

Use the following color scheme for wiring the quick disconnect adapter:

Color	Terminal	Description
White	+	24VDC+
Blue	-	24VDC-
Green/yellow	Grounding screw	Earth ground
Brown	B	Modbus A
Black	A	Modbus B

For direct wiring, wire to the following chart (color coding for Fireye cable 59-565 is shown):

CM-420 Terminal	FXO2TRIM-1 Terminal	59-565 Color
P1	+	Red
P2	-	Black
G	Grounding screw	Bare
P3	B	Orange
P4	A	Brown



### Quick Disconnect Cord Sets

Pre-made cord sets having female connectors on both ends are available in 1.83m (6 ft.) and 12.19m (40 ft.) lengths.

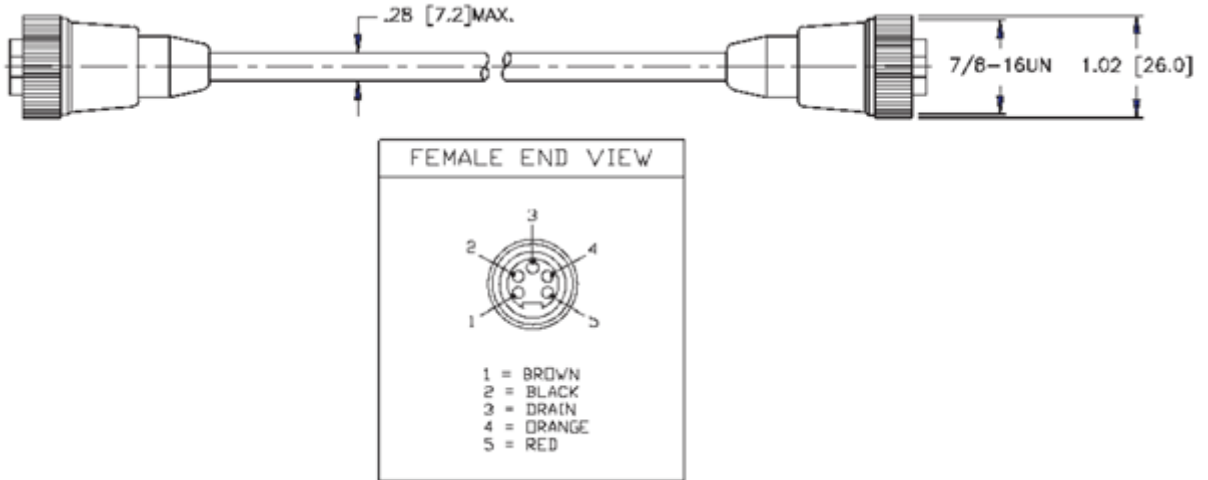



## Quick Disconnect Field Wiring

Quick disconnect connectors are available in kit form for field wiring (Fireeye part number 129-192). Two are needed per cord, one for each end. The recommended cable is Fireeye part number 59-565 (sold by the foot).

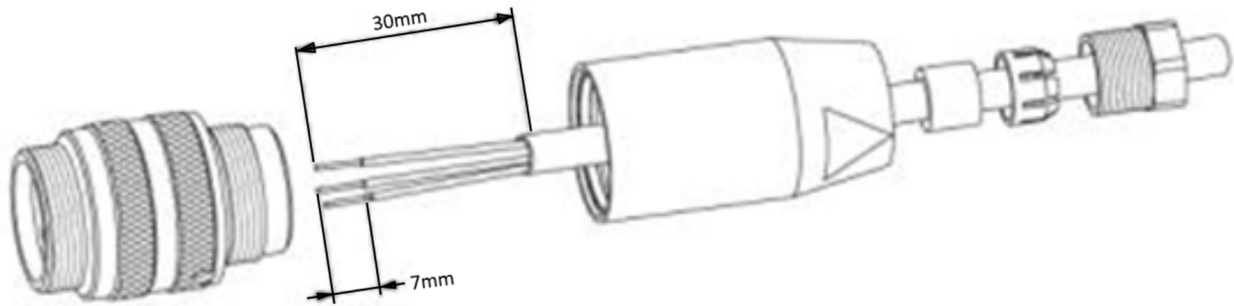

As shown above the cable strip length is specified at 30 mm (1.2 in) and each wire strip length is 7 mm (0.275 in).

To use cable 59-565, strip one end as specified. Strip each wire and wire to connector as shown in the image and table below:

Terminal	Description	Color (59-565 cable)
1	Modbus B	Brown
2	24VDC-	Black
3	Earth ground	Bare
4	Modbus A	Orange
5	24VDC+	Red

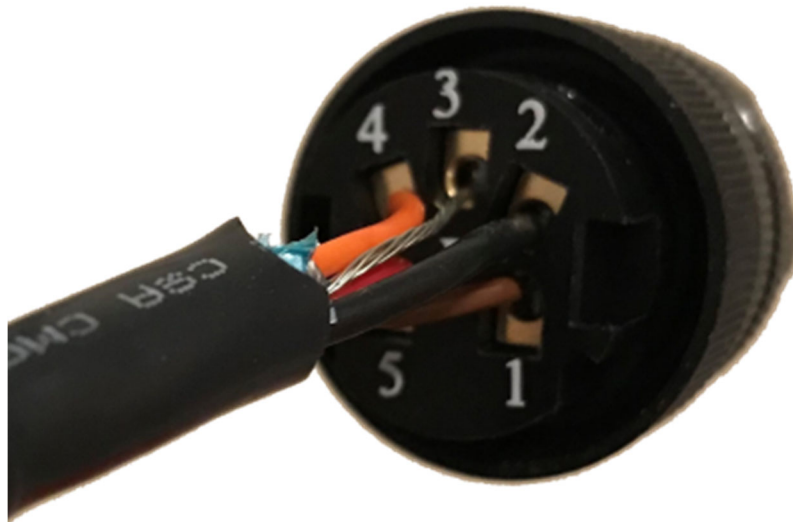



## INTERFACE

The touchscreen is used for configuration and monitoring of data.

### Navigation

The first screen that appears after power-up is the STATUS screen.

The screenshot shows the 'CM-420 COMBUSTION MONITOR' status screen. It features the Fireeye logo in the top left. The main display area shows several sensor readings: Oxygen In Situ (8.53%), Analog Output (9.5mA), Stack Gross (273F), Inlet Temp. (84F), Stack Net (189F), and Aux Analog (5.23%). Below these readings are four status boxes: Thermocouple OK, Ambient OK, Probe CPU OK, and Probe Sensor OK. At the bottom left, the time is 07:28 and the date is 10/21/2015. A 'Commands' button is located at the bottom center. On the right side, there are four alarm relay status indicators, all set to 'Off': Alarm Relay 1, Alarm Relay 2, Alarm Relay 3, and Alarm Relay 4. Below these are 'Oxygen Low MR' and 'Oxygen High MR' indicators. A 'Passcode' field is shown with a star icon and the word 'Locked' in red. A 'Main Menu' button is located at the bottom right.

This screen displays the operating information for the connected oxygen probe, as well as providing access to the main menu for navigation to other screens.

Only data that is configured will appear on the STATUS screen. For example, if an inlet temperature sensor is not fitted, the area where the inlet temperature and the net stack temperature are shown will be blank (net stack temperature is calculated by subtracting the inlet temperature from the gross stack temperature, which is the temperature read by the thermocouple in the oxygen probe).

The status of the stack thermocouple, ambient temperature sensor, probe CPU and probe O<sub>2</sub> sensor are all indicated on the STATUS screen. If the status is "OK", the boxes (status lamps) will be green. If there is a fault, the status lamp will be red. For the probe sensor, the status lamp can also be blue when it is calibrating, or orange when the probe is in standby or when it is warming up. These are the four internal "modules" of the oxygen probe. If a fault is indicated, navigating to the INFORMATION screen will provide additional data.

The area on the right side of the screen shows the settings and current status for the programmable alarm relays. If the reset type is set to manual reset, a RESET pushbutton will appear beside the status lamp when the alarm is active, to allow a reset.





## Probe Commands

Commands can be sent to the probe by pressing the COMMANDS pushbutton.

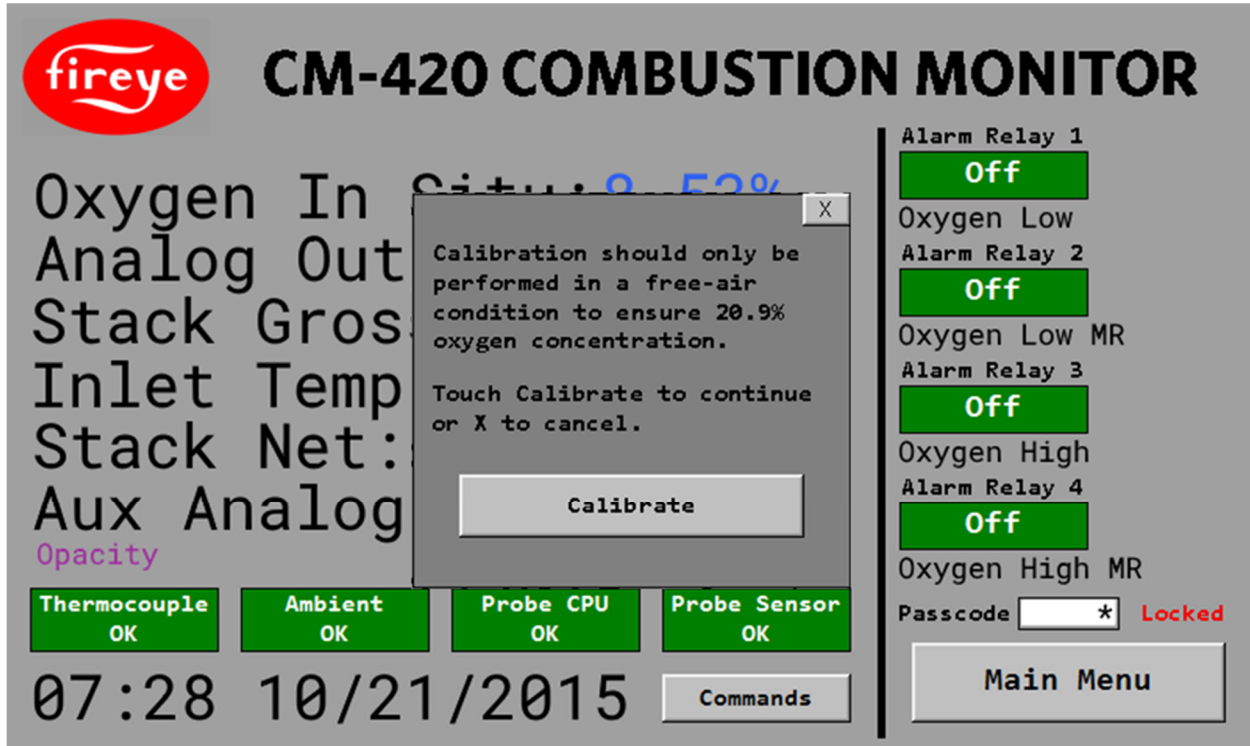

A pop-up window will appear allowing commands to be sent.

**CALIBRATE:** Send a calibration signal to the probe. As the warning indicates, this should only be performed in a free-air condition to ensure 20.9% oxygen concentration. Prior to calibration, the combustion air fan is typically allowed to purge for at least five minutes to ensure this condition is met.



## Main Menu

The main menu will be displayed if MAIN MENU is pressed.

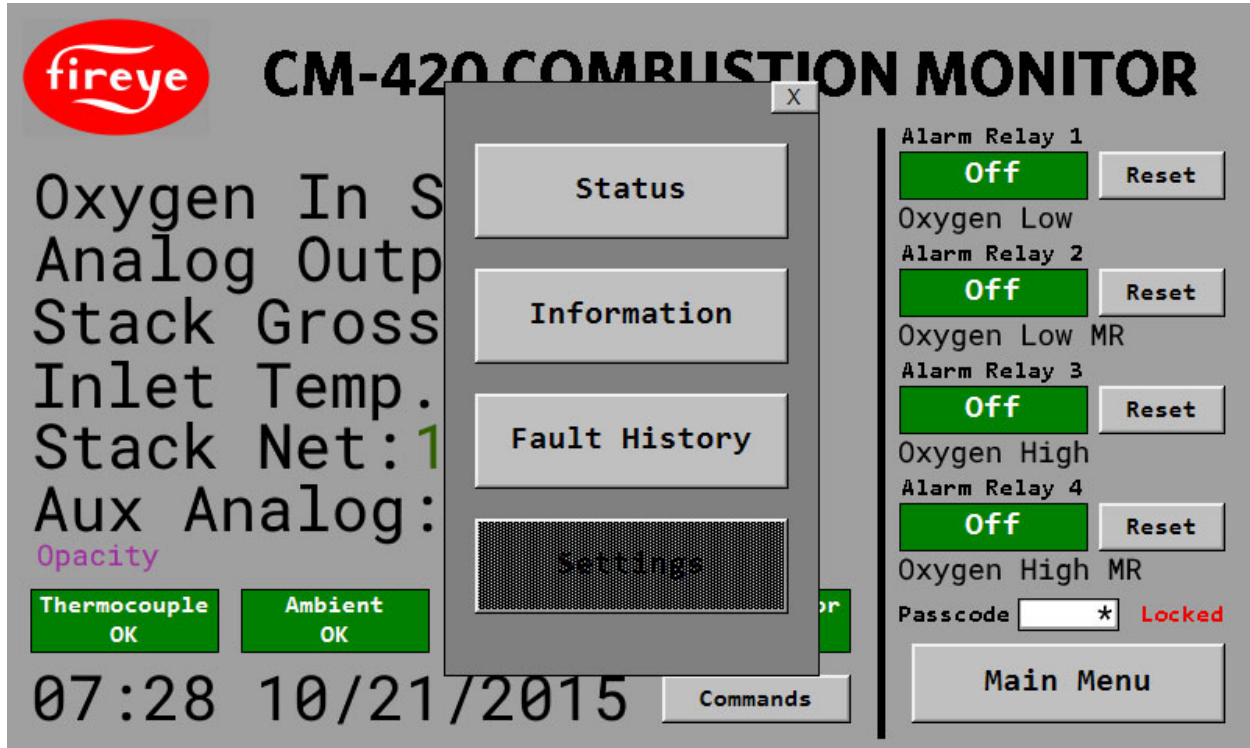

**STATUS:** This is the overview screen shown at power-up.

**INFORMATION:** This screen shows additional probe information such as detailed status and ambient temperature.

**FAULT HISTORY:** Shows the codes for the last ten faults in the oxygen probe memory. This button will only be available when the connected probe type is NXCESO2.

**SETTINGS:** The accesses all the CM-420 configuration area. A passcode is required to enter these screens. If the passcode area above the MAIN MENU button shows “Locked” in red, SETTINGS will appear hashed out. If the passcode is successfully entered, “Unlocked” will appear in green and the SETTINGS button will be accessible.

The passcode is fixed to **903**. Touch the entry area (indicated by one or more asterisks) to enter the passcode.



## Information

The information screen will be displayed if INFORMATION is pressed from the main menu.

The status information, COMMANDS button, MAIN MENU button and alarm relay information shown on the STATUS screen are also shown on the INFORMATION screen.

The static probe information related to firmware is shown, as well as the software revision of the CM-420. The probe ambient temperature is also displayed. More detailed status information is also shown for the stack thermocouple, ambient temperature, probe CPU and probe sensor. The text will be in green when the status is no fault and will be in red if the status is a fault. As with the status lamp, the probe sensor status will be in blue when calibrating and in orange when in standby or warming up.

See the Modbus Mapping section for a complete list of all the possible status messages.



## Fault History

The fault history screen will be displayed if FAULT HISTORY is pressed from the main menu. Note that only the NXCESO2 probe has a fault history. This page is not accessible when the connected probe is the FXCESO2 with FXO2TRIM-1 interface.

The screenshot displays the CM-420 Combustion Monitor interface. At the top left is the Fireeye logo. The main title is "CM-420 COMBUSTION MONITOR". Below the title is a table of fault history with columns: Fault, Module, Type, Sub-Type, Data (UI), and Data (I). The table lists faults from -1 to -9, with the latest fault being "02" with a sub-type of "2". Below the table are four status indicators: Thermocouple OK, Ambient OK, Probe CPU OK, and Probe Sensor OK. At the bottom left, the time is 07:28 and the date is 10/21/2015. To the right of the date is a "Commands" button. On the right side of the screen, there are four alarm relay status indicators: Alarm Relay 1 (Oxygen Low), Alarm Relay 2 (Oxygen Low MR), Alarm Relay 3 (Oxygen High), and Alarm Relay 4 (Oxygen High MR). Each relay is currently "Off" and has a "Reset" button. Below the relays is a "Passcode" field with a star icon and the word "Locked". At the bottom right is a "Main Menu" button.

Fault	Module	Type	Sub-Type	Data (UI)	Data (I)
<b>Latest</b>	02	0	2	65282	-254
-1	Stack	0	0	32764	32764
-2	***	0	0	65535	-1
-3	***	0	0	65535	-1
-4	***	0	0	65535	-1
-5	***	0	0	65535	-1
-6	***	0	0	65535	-1
-7	***	0	0	65535	-1
-8	***	0	0	65535	-1
-9	***	0	0	65535	-1

The status information, COMMANDS button, MAIN MENU button and alarm relay information shown on the STATUS screen are also shown on the INFORMATION screen.

For each fault, the relevant module (stack thermocouple, ambient temperature, probe CPU or probe sensor) will be displayed. Faults can also display as "Internal" or "Modbus" as well. Following the module, the type and sub-type of fault will be shown, as well as the contents of the data register which varies depending upon the module, type and sub-type combination. As such, the data is shown both unsigned (positive number only) and signed (positive or negative number).

For more detail on the faults, reference Fireeye bulletin *NXCESO2-1001*.



## SETTINGS

The settings screens share a common set of menu buttons located on the right-hand side of the page. The first settings screen show will be the general settings screen.

### General

This screen shows general screen-related settings.

Temperature Display Units	Imperial	General	
Date Display Format	DD/MM/YYYY	Probe	
Screen Beep On Touch	Off	Analog Inputs	
Screen Saver Function	Off	Analog Output	
Screen Saver (minutes)	20	Alarm Relays	
Hour	+1 -1	Date	+1 -1
Minute	+1 -1	Month	+1 -1
		Year	+1 -1
07:28 10/21/2015		Network	
		Main Menu	

**TEMPERATURE DISPLAY UNITS:** Selects whether to show temperatures on the STATUS and INFORMATION screens in Imperial units (degrees Fahrenheit) or in Metric units (degrees Celsius).

**DATA DISPLAY FORMAT:** Choose whether to show the date as DD/MM/YYYY or MM/DD/YYYY.

**SCREEN BEEP ON TOUCH:** Enables or disables the audible beep when the screen is touched.

**SCREEN SAVER FUNCTION:** Enables or disables the screen saver function.

**SCREEN SAVER:** If screen saver is enabled, sets the minutes before screen is blanked.

**TIME/DATE SETTINGS:** Adjust an element of the real-time clock +/- 1 unit.



## Probe

This screen shows probe-related settings. Changing values here changes the corresponding values in the probe memory.

Probe Type Fitted	NXCESO2		General
Start-up Delay (minutes)	5		Probe
Not Running Threshold (%)	18		Analog Inputs
Auto Calibration (hours)	24		Analog Output
Stack Temp. Max Limit	1562 F	850 C	Write New
Ambient Upper Limit	221 F	105 C	Write New
Ambient Lower Limit	-13 F	-25 C	Write New
07:28 10/21/2015			Alarm Relays
			Network
			Main Menu

**PROBE TYPE FITTED:** Selects whether the connected probe type is the NXCESO2 or the FXCESO2 with the FXO2TRIM-1 interface. This selection will enable/disable buttons and features that are not applicable to the connected probe.

**START-UP DELAY:** Sets the delay in minutes after powering up before any high O<sub>2</sub> level alarms can be generated. This gives the heater enough time to warm the oxygen probe if the connected appliance is idle.

**NOT RUNNING THRESHOLD:** Sets the threshold in O<sub>2</sub> percent where the appliance is assumed to be idle. Any reading above this threshold will not trigger a high O<sub>2</sub> level alarm. Automatic calibration can only occur when in this state for greater than five minutes.

**AUTO CALIBRATION:** Sets the delay in hours before the command to initiate automatic calibration. Once this command is issued, the probe must be in the not running state for greater than five minutes before the calibration command is sent. Setting this option to 0 will disable automatic calibration. Note that calibration is a logical process that sets the idle state reading (20.9%) and should only be done in a free air condition (no combustion gas present).



---

**STACK TEMP. MAX LIMIT:** Enter a value in either °F or °C and the corresponding value will change as well. Touch WRITE NEW to send the value to the oxygen probe. The allowed range to set is from 38°C to 1024°C (100°F to 1875°F), while the default setting is 482°C (900°F). A stack thermocouple reading above this value will cause the oxygen probe to issue a status fault for the stack thermocouple module. This setting will only be enabled when the connected probe type is NXCESO2. Note that the preferred method of monitoring the stack temperature is to use a programmable relay output, set to monitor a high stack temperature.

**AMBIENT UPPER LIMIT:** Set using the same method shown above. The allowed range to set is from 65°C to 125°C (149°F to 257°F), while the default setting is 85°C (185°F). An ambient temperature reading above this value will cause the oxygen probe to issue a status fault for the ambient temperature module. This setting will only be enabled when the connected probe type is NXCESO2.

**AMBIENT LOWER LIMIT:** Set using the same method shown above. The allowed range to set is from -15°C to -55°C (5°F to -67°F), while the default setting is -25°C (-13°F). An ambient temperature reading above this value will cause the oxygen probe to issue a status fault for the ambient temperature module. This setting will only be enabled when the connected probe type is NXCESO2.



## Analog Inputs

This screen allows configuration of the two analog inputs.

Use Inlet Sensor	<input type="text" value="Yes"/>	
Inlet Sensor Scale Low	<input type="text" value="-40"/> F	<input type="text" value="-40"/> C
Inlet Sensor Scale High	<input type="text" value="140"/> F	<input type="text" value="60"/> C
Use Aux 4-20mA Input	<input type="text" value="Yes"/>	
Aux 4-20mA Input Name	<input type="text" value="Aux Input"/>	
Aux 4-20mA Input Scale Low	<input type="text" value="40"/>	
Aux 4-20mA Input Scale High	<input type="text" value="200"/>	
Suffix	<input type="text" value="mA"/>	Decimal Accuracy <input type="text" value="1"/>

07:28 10/21/2015

General

Probe

Analog Inputs

Analog Output

Alarm Relays

Network

Main Menu

**USE INLET SENSOR:** Enables or disables use of an inlet temperature sensor. While not required the inlet temperature sensor allows calculation of a net stack temperature. This can make monitoring the stack temperature more accurate. It can also be useful for the PLC/SCADA/BMS to calculate efficiency.

**INLET SENSOR SCALE (LOW/HIGH):** Displays only when using the inlet sensor. Enter a value in either °F or °C and the corresponding value will change as well. This sets the range of the sensor used. The default settings match those of Fireeye part FXIATS-140 but any 4-20mA sensor can be used.

**USE AUX 4-20mA INPUT:** Enables or disables use of an auxiliary sensor. This can be any type of 4-20mA signal.

**AUX 4-20mA INPUT NAME:** Displays only when using the auxiliary input. Up to 20 string characters can be entered for the name (will be shown on the STATUS screen). Note that the auxiliary input display on the STATUS screen can only show a total of 10 characters. This includes the value, decimal point and suffix. If the range is too large the suffix may truncate.

**INLET SENSOR SCALE (LOW/HIGH):** Displays only when using the auxiliary input. The values entered can be from -2147483648 to 2147483647, allowing use of a wide variety of sensors. If the low scale is higher than the high scale, the output will scale in reverse (4mA is maximum, 20mA is minimum).

**SUFFIX:** Displays only when using the auxiliary input. Up to 4 string characters can be entered for the suffix/units of the auxiliary input (will be shown on the STATUS screen).

**DECIMAL ACCURACY:** Displays only when using the auxiliary input. Choose from 0 to 2 decimals.





## Analog Output

This screen allows configuration of the analog output.

Oxygen Reading at 4mA Output	<input type="text" value="0"/> %	General Probe Analog Inputs Analog Output Alarm Relays Network Main Menu
Oxygen Reading at 20mA Output	<input type="text" value="25"/> %	

07:28 10/21/2015

**OXYGEN READING AT 4mA OUTPUT:** Sets the O<sub>2</sub> value that will be represented by 4mA. Any value below this amount will also read as 4mA. The default is 0%.

**OXYGEN READING AT 20mA OUTPUT:** Sets the O<sub>2</sub> value that will be represented by 20mA. Any value above this amount will also read as 20mA. The default is 25%. Note that the maximum O<sub>2</sub> value read by the oxygen probe should be around 20.9%.

NOTE: If the value entered for 4mA is higher than the value entered for 20mA, the output will scale in reverse. In this case, any value above the 4mA setting will read as 4mA, and any value below the 20mA setting will read as 20mA.



## Alarm Relays

Each programmable alarm relay has a separate configuration screen. The options for each are the same. Use the << and >> buttons to scroll between the different configuration screens.

The default settings for the programmable alarms are:

- **ALARM 1:** Oxygen Low Limit, Automatic Reset, Setpoint 2.0%, No Delay (Oxygen Low)
- **ALARM 2:** Oxygen Low Limit, Manual Reset, Setpoint 1.0%, No Delay (Oxygen Low-Low)
- **ALARM 3:** Oxygen High Limit, Automatic Reset, Setpoint 12.0%, No Delay (Oxygen High)
- **ALARM 4:** Oxygen High Limit, Manual Reset, Setpoint 13.0%, No Delay (Oxygen High-High)

The screenshot shows the configuration screen for Alarm 1. On the left, there are four rows of settings, each with a label and a button: 'Alarm 1 Function' with 'Probe Error', 'Alarm 1 Output Polarity' with 'Closed = Alarm (N.O.)', 'Alarm 1 Reset Type' with 'Automatic Reset', and 'Alarm 1 Delay Function' with 'No Delay'. On the right, a vertical menu contains buttons for 'General', 'Probe', 'Analog Inputs', 'Analog Output', 'Alarm Relays', 'Network', and 'Main Menu'. At the bottom, the time and date are displayed as '07:28 10/21/2015', with navigation buttons '<<' and '>>'.

**ALARM x FUNCTION:** Sets the function for the programmable alarm relay. Choices are:

- **PROBE ERROR:** The condition will be true if any of the four modules (stack thermocouple, ambient temperature, probe CPU or probe sensor) indicate a fault condition.
- **CALIBRATING:** The condition will be true if the oxygen probe is calibrating.
- **OXYGEN LOW LIMIT:** Compares the O<sub>2</sub> reading to the setpoint to set the condition. Condition is true when the reading is below the setpoint.
- **OXYGEN HIGH LIMIT:** Compares the O<sub>2</sub> reading to the setpoint to set the condition. Condition is true when the reading is above the setpoint for longer than the filter delay time of five minutes. Note that the reading must be at or below the NOT RUNNING THRESHOLD for an alarm to be true. The boiler or appliance is offline when the reading is above NOT RUNNING THRESHOLD.



- **STACK LOW LIMIT:** Compares the net stack reading to the setpoint to set the condition. Condition is true when the reading is below the setpoint and the O2 reading is below the NOT RUNNING THRESHOLD, for the longer than the filter delay time of five minutes. If the inlet sensor is not optioned (i.e. net stack temperature can't be calculated), then the gross stack temperature is used.
- **STACK HIGH LIMIT:** Compares the net stack reading to the setpoint to set the condition. Condition is true when the reading is above the setpoint. If the inlet sensor is not optioned (i.e. net stack temperature can't be calculated), then the gross stack temperature is used.
- **AUX LOW LIMIT:** Compares the auxiliary input reading to the setpoint to set the condition. Condition is true when the reading is below the setpoint.
- **AUX HIGH LIMIT:** Compares the auxiliary input reading to the setpoint to set the condition. Condition is true when the reading is above the setpoint.
- **MODBUS CONTROL:** The condition is directly set by writing via Modbus (allows PLC/SCADA/BMS direct control of the output).
- **COMM. LOSS:** The condition is true when communication between the NXCESO2 or FXO2TRIM-1 and CM-420 is lost.

**ALARM x OUTPUT POLARITY:** Choose whether the relay should be closed when the condition is true (CLOSED = ALARM) or when the condition is false (OPEN = ALARM).



**WARNING:** Do not use the relay outputs for safety related connections. For example, do not set up a programmable relay output to monitor high stack temperature with the output set to be open with alarm if this is expected to be a primary safety device. This can be done if it is not required or is an optional safety device.

**ALARM x RESET TYPE:** Choose whether the condition will latch. Choosing AUTOMATIC will result in the condition automatically changing states (alarm clears). Choosing MANUAL will result in the condition remaining true indefinitely unless reset using the RESET button for the respective alarm relay.

**ALARM x DELAY FUNCTION:** Choose whether there should be a delay before the alarm condition is true or a delay before the alarm condition is released. Choices are:

- **NO DELAY:** Condition is immediate.
- **DELAY ON MAKE:** Condition is not true until the delay setpoint has elapsed. The condition must remain true during the entire timing period. This can be used to filter out nuisance setpoint crossings to ensure that the condition is true.
- **DELAY ON BREAK:** Output remains on after the condition is no longer true until the delay setpoint has elapsed.

**ALARM x DELAY SETPOINT:** Displays only when using a delay. Sets how long the timer delays on make or on break in seconds. Can be set up to 9999 seconds.



Additional settings will be shown when the alarm type is set to monitor O<sub>2</sub>, stack or auxiliary input low or high limits (screen shown for O<sub>2</sub> limit).

<b>Alarm 1 Function</b>	Oxygen Low Limit	<b>General</b>	
<b>Alarm 1 Output Polarity</b>	Closed = Alarm (N.O.)		<b>Probe</b>
<b>Alarm 1 Reset Type</b>	Automatic Reset		<b>Analog Inputs</b>
<b>Alarm 1 Setpoint Oxygen</b>	? 2.0 %		<b>Analog Output</b>
<b>Alarm 1 Delay Function</b>	No Delay		<b>Alarm Relays</b>
		<b>Network</b>	
		<b>Main Menu</b>	

07:28 10/21/2015 << >>

**ALARM x SETPOINT OXYGEN:** Choose the setpoint for the low or high O<sub>2</sub> limit. A help button is provided that explains the high limit alarm is only valid to the NOT RUNNING THRESHOLD option (the boiler or appliance is considered offline if the O<sub>2</sub> reading is above the NOT RUNNING THRESHOLD option).

**ALARM x SETPOINT STACK TEMP.:** Choose the setpoint for the low or high stack temperature limit. Enter a value in either °F or °C and the corresponding value will change as well.

**ALARM x SETPOINT AUX INPUT:** Choose the setpoint for the low or high auxiliary input limit. The value can be either negative or positive and is entered without decimal accuracy. This means that if the auxiliary input is using two decimals to represent a value from -50.00 to 200.00 and the setpoint desired is 75.25, the setpoint can only be entered as either 75 or 76.



## Network

The setting for the Modbus connections can be set from this screen. Modbus TCP/IP is available from the Ethernet port on the rear of the touchscreen interface. Modbus RTU is available from the COM2 port on the rear of the touchscreen interface. See the MODBUS CONNECTION section for further connection information.

IP Address	192	168	0	11	General Probe Analog Inputs Analog Output Alarm Relays Network Main Menu
Subnet Mask	255	255	255	0	
Default Gateway	0	0	0	0	
Modbus RTU Node Address				1	
Modbus RTU Baud Rate				38400	
Modbus RTU Data Bits				8	
Modbus RTU Parity				None	
Modbus RTU Stop Bits				1	
07:28 10/21/2015					

All settings will be applied immediately to non-volatile memory – no reboot is required.

**IP ADDRESS:** Sets the IP address. There is a separate entry for each byte. Each byte can be set from 0 to 255. The default is 192.168.0.11.

**SUBNET MASK:** Sets the subnet mask. There is a separate entry for each byte. Each byte can be set from 0 to 255. The default is 255.255.255.0.

**DEFAULT GATEWAY:** Sets the IP address. There is a separate entry for each byte. Each byte can be set from 0 to 255. The default is 0.0.0.0.

**MODBUS RTU NODE ADDRESS:** Sets the node address. This can be set from 1 to 255 (default is 1).

**MODBUS RTU BAUD RATE:** Sets the baud rate. Choices are 4800, 9600, 19200, 38400, 57600, 115200 or 187500 (default is 38400).

**MODBUS RTU DATA BITS:** Sets the data bits. Choices are 7 or 8 (default is 8).

**MODBUS PARITY:** Sets the parity. Choices are none, even, odd (default is none).

**MODBUS RTU STOP BITS:** Sets the stop bits. Choices are 1 or 2 (default is 1).



## MODBUS

Modbus is available in either a TCP/IP connection or an RTU connection. The mapping is the same for each – see the MODBUS MAPPING section for a complete list.

All Modbus data is contained in holding registers (4x type). Use function code 3 to read the holding registers. Bit data is contained in complete words, coil and input registers are not used. Any writes to data can use either function code 6 or function code 16. The valid register area is from 40001 to 40140. Any reads/writes must begin and end in this range. There is no limit from the server side as to how many registers can be read consecutively.

### Modbus Connection

The Modbus TCP/IP connection uses standard Cat5 cabling and Ethernet topology. If the connection is made directly to another device, automatic switching will take place, so a crossover cable is not required. Make sure that the IP address is not duplicated, or a pop-up window will appear to allow the IP address to be changed. Note that this pop-up is automatic and will allow DHCP to be selected. Do not select DHCP as doing so may make it difficult to locate the device on the network.

The Modbus RTU connection is made to the DB9 female connector on COM2. This connector supports RS232, RS422 or RS485. A custom cable can be made or a connector such as the DGB9MT1 from L-Com can be used to convert to terminals (image shown below).

DB connectors have standard pin numbers from 1 to 9. These are shown in the table below with the corresponding functions:

DB9 Pin	Function
1	RS422/RS485 Tx+
2	RS232 Transmit
3	RS232 Receive
4	RS422/RS485 Rx+
5	Ground
6	No connection
7	No connection
8	RS422/RS485 Tx-
9	RS422/RS485 Tx-



L-Com DGB9MT1

Connection diagrams:

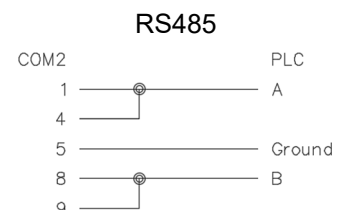
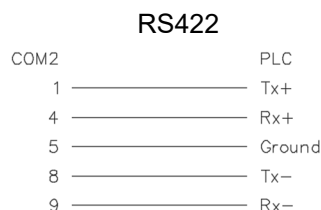
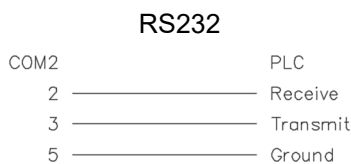



## Modbus Mapping

Read access is shown with **R** and write access is shown with **W**.

Data types:

- **UINT** (unsigned integers, occupies a single register)
- **REAL** (floating point IEEE 754, occupies two consecutive registers)
- **STRING** (single register of two ASCII characters)
- **HEX** (single register to be read in hexadecimal)

Where bit data is packed into UINT registers, bit positions are indicated.

Address	Bit	Access	Type	Description	Notes
40001	---	R	UINT	O <sub>2</sub> percent	Data is x100 65535 = invalid
40002	---	R	UINT	Analog output 4-20mA	Data is x10 65535 = invalid
40003	---	R	REAL	Stack temperature, gross (°C)	-1 = invalid
40005	---	R	REAL	Stack temperature, gross (°F)	-1 = invalid
40007	---	R	REAL	Inlet temperature (°C)	-1 = invalid
40009	---	R	REAL	Inlet temperature (°F)	-1 = invalid
40011	---	R	REAL	Stack temperature, net (°C)	-1 = invalid
40013	---	R	REAL	Stack temperature, net (°F)	-1 = invalid
40015	---	R	REAL	Probe ambient temperature (°C)	-1 = invalid
40017	---	R	REAL	Probe ambient temperature (°F)	-1 = invalid
40019	---	R	REAL	Auxiliary input	-1 = invalid
40021	---	RW	UINT	Command bits	See note 7
---	0	RW	Bit	Calibrate command	
---	4	RW	Bit	Alarm relay 1 manual command	
---	5	RW	Bit	Alarm relay 2 manual command	
---	6	RW	Bit	Alarm relay 3 manual command	
---	7	RW	Bit	Alarm relay 4 manual command	
40022	---	R	UINT	Status bits	
---	0	R	Bit	Stack thermocouple OK	
---	1	R	Bit	Stack thermocouple error	
---	2	R	Bit	Probe CPU OK	
---	3	R	Bit	Probe CPU error	
---	4	R	Bit	Ambient temperature OK	
---	5	R	Bit	Ambient temperature error	
---	6	R	Bit	Probe sensor OK	
---	7	R	Bit	Probe sensor error	
---	8	R	Bit	Probe sensor calibrating	
---	9	R	Bit	Probe sensor in standby	



Address	Bit	Access	Type	Description	Notes
---	10	R	Bit	Display units	0 = imperial 1 = metric
---	11	R	Bit	Communication to NXCESO2 or FXO2TRIM-1 active	0 = comm. loss 1 = active
40023	---	R	UINT	Alarm relay 1 status bits	
---	0	R	Bit	Alarm condition	0 = condition false 1 = condition true
---	1	R	Bit	Alarm relay status	0 = relay open 1 = relay closed
40024	---	R	UINT	Alarm relay 2 status bits	
---	0	R	Bit	Alarm condition	0 = condition false 1 = condition true
---	1	R	Bit	Alarm relay status	0 = relay open 1 = relay closed
40025	---	R	UINT	Alarm relay 3 status bits	
---	0	R	Bit	Alarm condition	0 = condition false 1 = condition true
---	1	R	Bit	Alarm relay status	0 = relay open 1 = relay closed
40026	---	R	UINT	Alarm relay 4 status bits	
---	0	R	Bit	Alarm condition	0 = condition false 1 = condition true
---	1	R	Bit	Alarm relay status	0 = relay open 1 = relay closed
40027	---	R	UINT	Stack thermocouple message	See note 2
40028	---	R	UINT	Probe CPU message	See note 3
40029	---	R	UINT	Ambient temperature message	See note 4
40030	---	R	UINT	Probe sensor message	See note 5
40031	---	R	STRING	Oxygen probe firmware revision	
40032	---	R	HEX	Oxygen probe firmware CRC	
40033	---	R	STRING	CM-420 software revision	
Fault history registers (see note 1, NXCESO2 only)					
40xx1	---	R	UINT	Fault module	See note 6
40xx2	---	R	UINT	Fault type	
40xx3	---	R	UINT	Fault sub-type	See Fireye bulletin <i>NXCESO2-1001</i>
40xx4	---	R	UINT	Fault data register	





---

**Note 1:** There are ten faults in the fault history. Each is organized with the same structure, using the following addresses:

- **Latest fault:** 40041-40044
- **History 1 fault:** 40051-40054
- **History 2 fault:** 40061-40064
- **History 3 fault:** 40071-40074
- **History 4 fault:** 40081-40084
- **History 5 fault:** 40091-40094
- **History 6 fault:** 40101-40104
- **History 7 fault:** 40111-40114
- **History 8 fault:** 40121-40124
- **History 9 fault:** 40131-40134

**Note 2:** Stack thermocouple messages. See Fireeye bulletin *NXCESO2-1001* for additional information.

- **0:** Stack Probe OK
- **1:** Stack Probe Disconnected Fault
- **2:** Stack Over Temperature Fault
- **3:** Stack Read Fault

**Note 3:** Probe CPU messages. See Fireeye bulletin *NXCESO2-1001* for additional information.

- **0:** CPU OK
- **1:** CPU CRC Fault
- **2:** CPU RAM Fault
- **3:** CPU Instruction Fault

**Note 4:** Ambient temperature messages. See Fireeye bulletin *NXCESO2-1001* for additional information.

- **0:** Ambient Temperature OK
- **1:** Ambient Temperature Cannot Be Read Fault
- **2:** Ambient Over Temperature Fault
- **3:** Ambient Under Temperature Fault



---

**Note 5:** Probe sensor messages. See Fireeye bulletin *NXCESO2-1001* for additional information.

- **0:** Sensor OK
- **1:** Sensor 24V Low Fault
- **2:** Sensor 24V High Fault
- **3:** Sensor 12V Open Fault
- **4:** Sensor 12V Low Fault
- **5:** Sensor 12V High Fault
- **6:** Sensor Unexpected Calibration Fault
- **7:** Sensor Stuck Fault
- **8:** Sensor Calibration Needed
- **9:** Sensor Heater Short Fault
- **10:** Sensor Heater Open Fault
- **11:** Sensor Pump Short Fault
- **12:** Sensor Pump Open Fault
- **13:** Sensor Nernst Cell Short Fault
- **14:** Sensor Nernst Cell Open Fault
- **15:** Sensor Conversion Timeout Fault
- **16:** Sensor Low Voltage Fault
- **17:** Sensor Too Cold Fault
- **18:** Sensor Too Hot Fault
- **19:** Sensor Air Calibrating
- **20:** Sensor Heater Calibrating
- **21:** Sensor Comm. Busy
- **22:** Sensor Comm. Fault
- **32:** Sensor Warming Up
- **33:** Sensor In standby

**Note 6:** Fault history module enumerations. See Fireeye bulletin *NXCESO2-1001* for additional information.

- **1:** CPU
- **2:** Stack thermocouple
- **3:** Ambient temperature
- **4:** Probe sensor
- **5:** Internal
- **6:** Modbus

**Note 7:** When writing commands, the bit must also be turned back off or the command will continue to execute (i.e. the CM-420 will continuously send a calibrate command to the NXCESO2 or FXO2TRIM-1). The best strategy is to issue the command and monitor the status bits and messages to determine when to turn the command off.



---

## CERTIFICATIONS

UL508A Enclosed Industrial Control Panel (United States/Canada)



---

## NOTICE

When Fireeye products are combined with equipment manufactured by others and/or integrated into systems designed or manufactured by others, the Fireeye warranty, as stated in its General Terms and Conditions of Sale, pertains only to the Fireeye products and not to any other equipment or to the combined system or its overall performance.

## WARRANTIES

FIREYE guarantees for one year from the date of installation or 18 months from date of manufacture of its products to replace or repair (Fireeye's option) any product or part thereof (except lamps and photocells) which is found defective in material or workmanship or which otherwise fails to conform to the description of the product on the face of its sales order. **THE FOREGOING IS IN LIEU OF ALL OTHER WARRANTIES AND FIREYE MAKES NO WARRANTY OF MERCHANT-ABILITY OR ANY OTHER WARRANTY, EXPRESS OR IMPLIED.** Except as specifically stated in these general terms and conditions of sale, remedies with respect to any product or part number manufactured or sold by Fireeye shall be limited exclusively to the right to replacement or repair as above provided. In no event shall Fireeye be liable for consequential or special damages of any nature that may arise in connection with such product or part.