

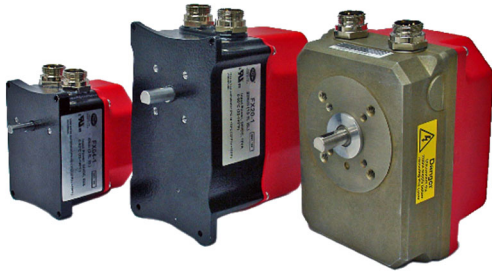

NEX-3001
January 18, 2022



Fireeye FX Series Modbus Controlled Actuator /Servo Installation and Wiring



DESCRIPTION

This bulletin describes the installation and operating instructions for the FX series of servo motors. These come in three sizes: FX04 (4Nm/3ft.-lb.), FX20 (20Nm/15ft.-lb.) and FX50 (50Nm/37ft.-lb.). There are available in two baud rates: 56k for use with the NXF4000 or PPC4000 parallel positioning system or 19.2k for general use with a PLC or other Modbus client. The FX04 size is also available in a 38.4k baud rate for general use with a PLC or other Modbus client. Only the 56k model is approved for use as part of a protective system (when used with the NXF4000 or PPC4000).

These servos are not compatible with or approved as replacements for the 945 series of servos.

SAFETY INFORMATION



WARNING: When this equipment is mounted onto an appliance, all external timers/controllers must be listed or recognized components and approved by national certification agencies for the purpose for which they are used and approved for use by a local authority who has jurisdiction.



WARNING – EXPLOSION HAZARD. DO NOT CONNECT OR DISCONNECT WHEN ENERGIZED.

SYSTEM INFORMATION

The Fireeye FX series servo motors are precision actuators designed to accurately position valves and dampers. The servo motor interprets Modbus commands from an external control and uses a stepper motor to drive to the commanded position.

The FX series servo motors offers maximum output torque ratings of 4Nm/3ft.-lb., 20Nm/15ft.-lb. or 50Nm/37ft.-lb. The fastest available travel time is 30 seconds for 90 degrees of rotation. The slowest travel time available varies by size. Maximum rotation angle of the drive shaft is 100 degrees.

The servo is designed to be applied to drive any type of flow control valve or damper as long as the output torque is suited to the application.

Before attempting to install, commission or operate this equipment all relevant sections of this document must be read and fully understood, failure to follow them could damage the product or cause a hazardous condition. If in doubt about any requirements consult the supplier.



Check the ratings in the following instructions to ensure the product is suitable for your application.

Installation, commissioning or adjustment of this product **MUST** be carried out by personnel qualified by local, state, regional or national requirements.

After installation is complete, check the product operation is as described in these instructions.

The manufacturer of this equipment accepts no liability for any consequences resulting from inappropriate, negligent or incorrect installation, commissioning or adjustment of operating parameters of the equipment.

These mounting and operating instructions are intended to give the knowledge which is necessary to carry out the mounting and adjustment of FX series servo motor safely and correctly.

NOTE: The manufacturer of this equipment has a policy of continual product improvement and reserves the right to change the specification of the equipment and the contents of this manual without notice.

TECHNICAL DATA FX04 VERSIONS

Fastest actuating time for 90° angle of rotation:	30 seconds
Slowest actuating time for 90° angle of rotation:	126 seconds
Nominal torque:	4Nm/3ft.-lb.
Maximum angle of rotation:	100°
Nominal voltage	24 VDC ± 10%
Nominal power consumption:	5W nominal, 7.5W peak
Angle of rotation limited by:	Firmware
Degree of protection:	NEMA 4 IP 65 (see note below)
Installation orientation:	Any
Working temperature range:	-4°F to +140°F (-20°C to +60°C)
Duty cycle:	100%
Weight:	2.27 lb. / 1.03 kg.

Note: For models without quick disconnect fittings, suitable conduit fittings that meet the desired protection are supplied by the application.



TECHNICAL DATA FX20 VERSIONS

Fastest actuating time for 90° angle of rotation:	30 seconds
Slowest actuating time for 90° angle of rotation:	368.4 seconds
Nominal torque:	20Nm/15ft.-lb.
Maximum angle of rotation:	100°
Nominal voltage	24 VDC ± 10%
Nominal power consumption:	15W nominal, 35W peak
Angle of rotation limited by:	Firmware
Degree of protection:	NEMA 4 IP 65 (see note below)
Installation orientation:	Any
Working temperature range:	-4°F to +140°F (-20°C to +60°C)
Duty cycle:	100%
Weight:	5.43 lb. / 2.46 kg.

Note: For models without quick disconnect fittings, suitable conduit fittings that meet the desired protection are supplied by the application.

TECHNICAL DATA FX50 VERSIONS

Fastest actuating time for 90° angle of rotation:	30 seconds
Slowest actuating time for 90° angle of rotation:	202.1 seconds
Nominal torque:	50Nm/37ft.-lb.
Maximum angle of rotation:	100°
Nominal voltage	24 VDC ± 10%
Nominal power consumption:	20W nominal, 38W peak
Angle of rotation limited by:	Firmware
Degree of protection:	NEMA 4 IP 65 (see note below)
Installation orientation:	Any
Working temperature range:	-4°F to +140°F (-20°C to +60°C)
Duty cycle:	100%
Weight:	6.10 lb. / 2.77 kg.

Note: For models without quick disconnect fittings, suitable conduit fittings that meet the desired protection are supplied by the application.



ORDERING INFORMATION

Servos for NXF4000/PPC4000 Parallel Positioning System (56k Baud)		Bulletin
FX04	Servo motor, 24 VDC operation, 4Nm, 3 ft.lb. torque, ½" NPT conduit threaded, minimum travel time of 30 seconds for 90°, 56k baud for NXF4000/PPC4000	NEX-3001
FX04-1	Servo motor, 24 VDC operation, 4Nm, 3 ft.lb. torque, quick disconnect connectors, minimum travel time of 30 seconds for 90°, 56k baud for NXF4000/PPC4000	
FX20	Servo motor, 24 VDC operation, 20Nm, 15 ft.lb. torque, ½" NPT conduit threaded, minimum travel time of 30 seconds for 90°, 56k baud for NXF4000/PPC4000	
FX20-1	Servo motor, 24 VDC operation, 20Nm, 15 ft.lb. torque, quick disconnect connectors, minimum travel time of 30 seconds for 90°, 56k baud for NXF4000/PPC4000	
FX50	Servo motor, 24 VDC operation, 50Nm, 37 ft.lb. torque, ½" NPT conduit threaded, minimum travel time of 30 seconds for 90°, 56k baud for NXF4000/PPC4000	
FX50-1	Servo motor, 24 VDC operation, 50Nm, 37 ft.lb. torque, quick disconnect connectors, minimum travel time of 30 seconds for 90°, 56k baud for NXF4000/PPC4000	
Servos for PLC or General Modbus Use (19.2k, 38.4k Baud)		Bulletin
FX04-19	Servo motor, 24 VDC operation, 4Nm, 3 ft.lb. torque, ½" NPT conduit threaded, minimum travel time of 30 seconds for 90°, 19.2k baud for PLC control	NEX-3001
FX04-119	Servo motor, 24 VDC operation, 4Nm, 3 ft.lb. torque, quick disconnect connectors, minimum travel time of 30 seconds for 90°, 19.2k baud for PLC control	
FX04-38	Servo motor, 24 VDC operation, 4Nm, 3 ft.lb. torque, ½" NPT conduit threaded, minimum travel time of 30 seconds for 90°, 38.4k baud for PLC control	
FX04-138	Servo motor, 24 VDC operation, 4Nm, 3 ft.lb. torque, quick disconnect connectors, minimum travel time of 30 seconds for 90°, 38.4k baud for PLC control	
FX20-19	Servo motor, 24 VDC operation, 20Nm, 15 ft.lb. torque, ½" NPT conduit threaded, minimum travel time of 30 seconds for 90°, 19.2k baud for PLC control	
FX20-119	Servo motor, 24 VDC operation, 20Nm, 15 ft.lb. torque, quick disconnect connectors, minimum travel time of 30 seconds for 90°, 19.2k baud for PLC control	
FX50-19	Servo motor, 24 VDC operation, 50Nm, 37 ft.lb. torque, ½" NPT conduit threaded, minimum travel time of 30 seconds for 90°, 19.2k baud for PLC control	
FX50-119	Servo motor, 24 VDC operation, 50Nm, 37 ft.lb. torque, quick disconnect connectors, minimum travel time of 30 seconds for 90°, 19.2k baud for PLC control	
Premade Quick Disconnect Cord Sets		Bulletin
59-565-6	Quick disconnect cord set, 6 feet, PVC jacket, temperature rating -40°C to 105°C, meets NEMA 1,3,4,6P and IEC67	133-748
59-565-40	Quick disconnect cord set, 6 feet, PVC jacket, temperature rating -40°C to 105°C, meets NEMA 1,3,4,6P and IEC67	
Connectors and Cable		Bulletin
129-192	Quick disconnect connector for field wiring, female (cable 59-565 recommended)	133-747
129-194	Quick disconnect connector for converting servos, male	n/a
59-565	Cable, twisted pair with drain wire, 2 power wires, suitable for servo hookup	n/a



SAFETY ADVICE

Device safety

The servo motor must only be used for purposes corresponding to its construction and within the values specified in the technical data.

The installer should be satisfied that no potential hazards will be produced for any devices or machines involved as a result of the installation or commissioning.

Before mounting the servo motor, check the free movement of the connected valve, damper or other device.

After completing the mounting and adjustment, check the correct functioning of the servo motor.

Safety advice for mounting and adjustments

The installer must be satisfied that no potential hazards will be produced for personnel or the environment as a result of the installation or commissioning.

After completing adjustments, check the correct functioning of the servo motor.

Check that any safety devices are functioning correctly.

Carry out adjustments only in accordance with the instructions described in this document.

Adjustments must be carried out only by a licensed or a qualified person having adequate training, who is aware of potential hazards.

Wiring

Five wires must be connected to power and communicate with the servo. Quick disconnecting cord sets are available for the FX04-1, FX04-119, FX04-38, FX04-138, FX20-1, FX20-119, FX50-1 and FX50-119. Quick disconnect fittings and cable are available for field construction and installation using the ½" NPT fitted models. Be sure to connect the ground connection first to eliminate any ESD (electrostatic discharge) potential.

SERVO MOTOR DIAGRAM

FX04 (FX04-1/FX04-119/FX04-138 with quick disconnects shown) diagram

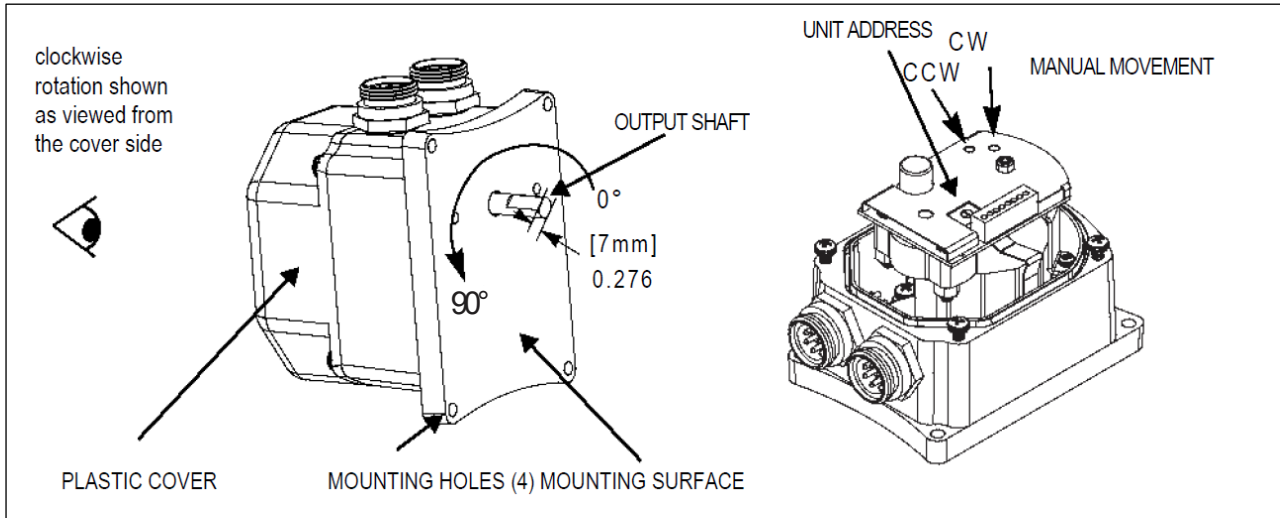

FX20 (FX20-1/FX20-119 with quick disconnects shown) diagram

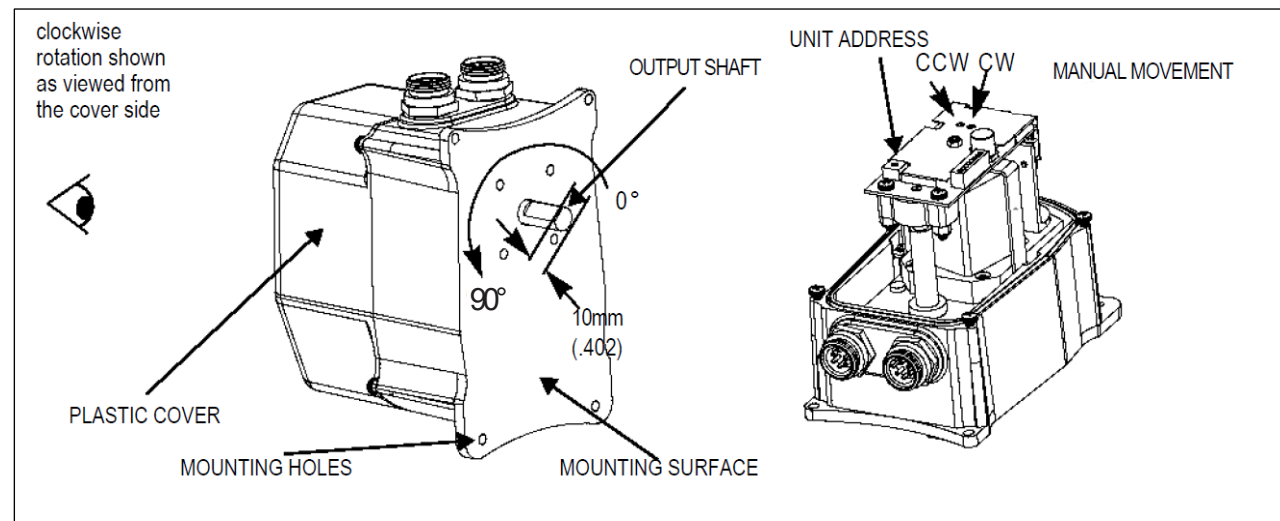

FX50 (FX50-1/FX50-119 with quick disconnects shown) diagram

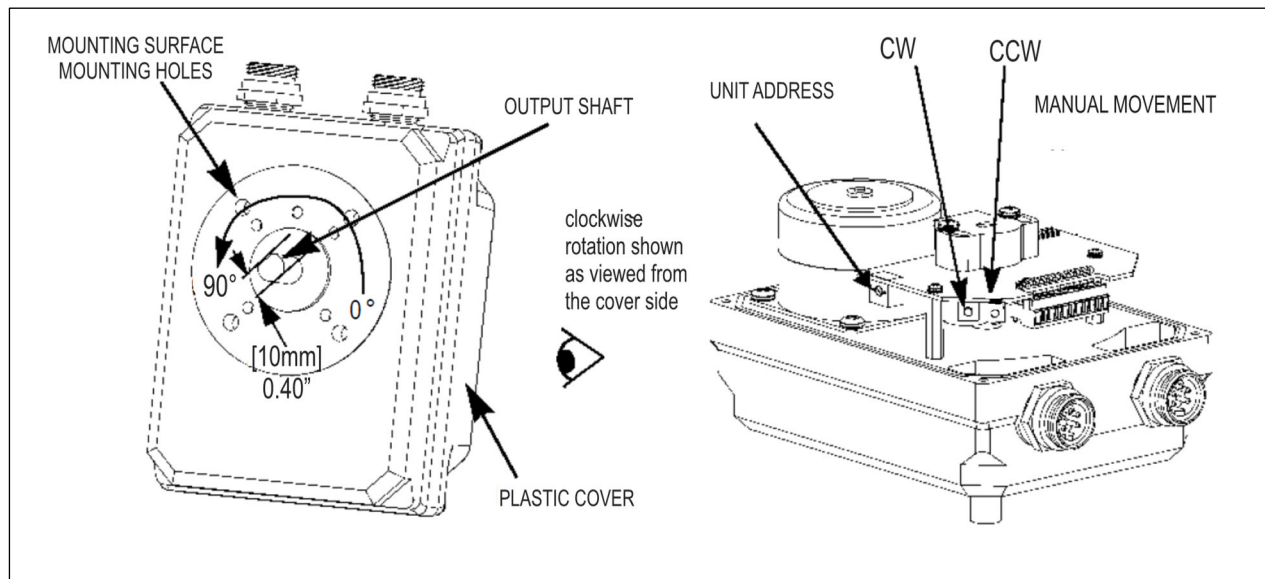



DIMENSIONS

FX04 dimensions

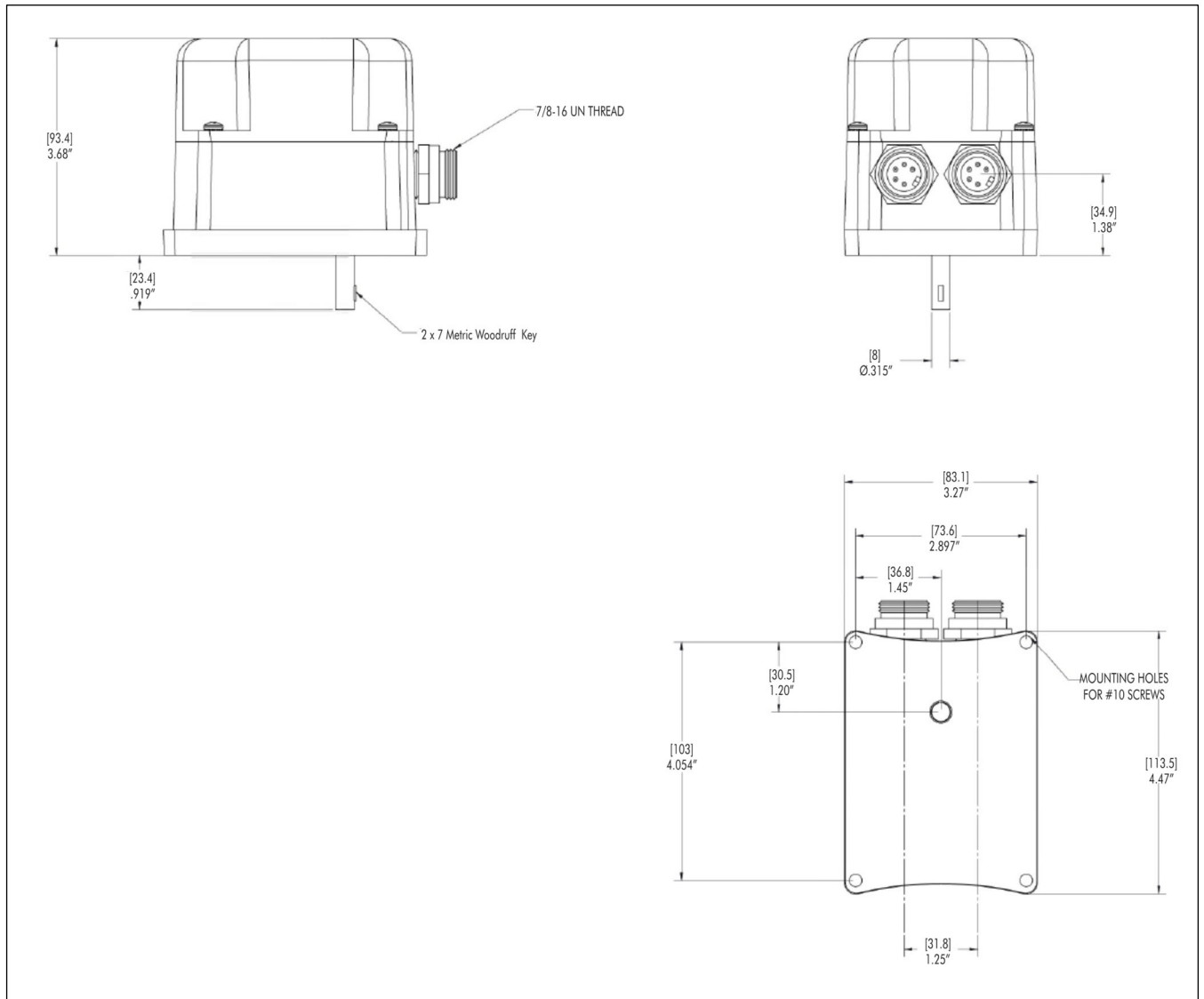



FX20 dimensions

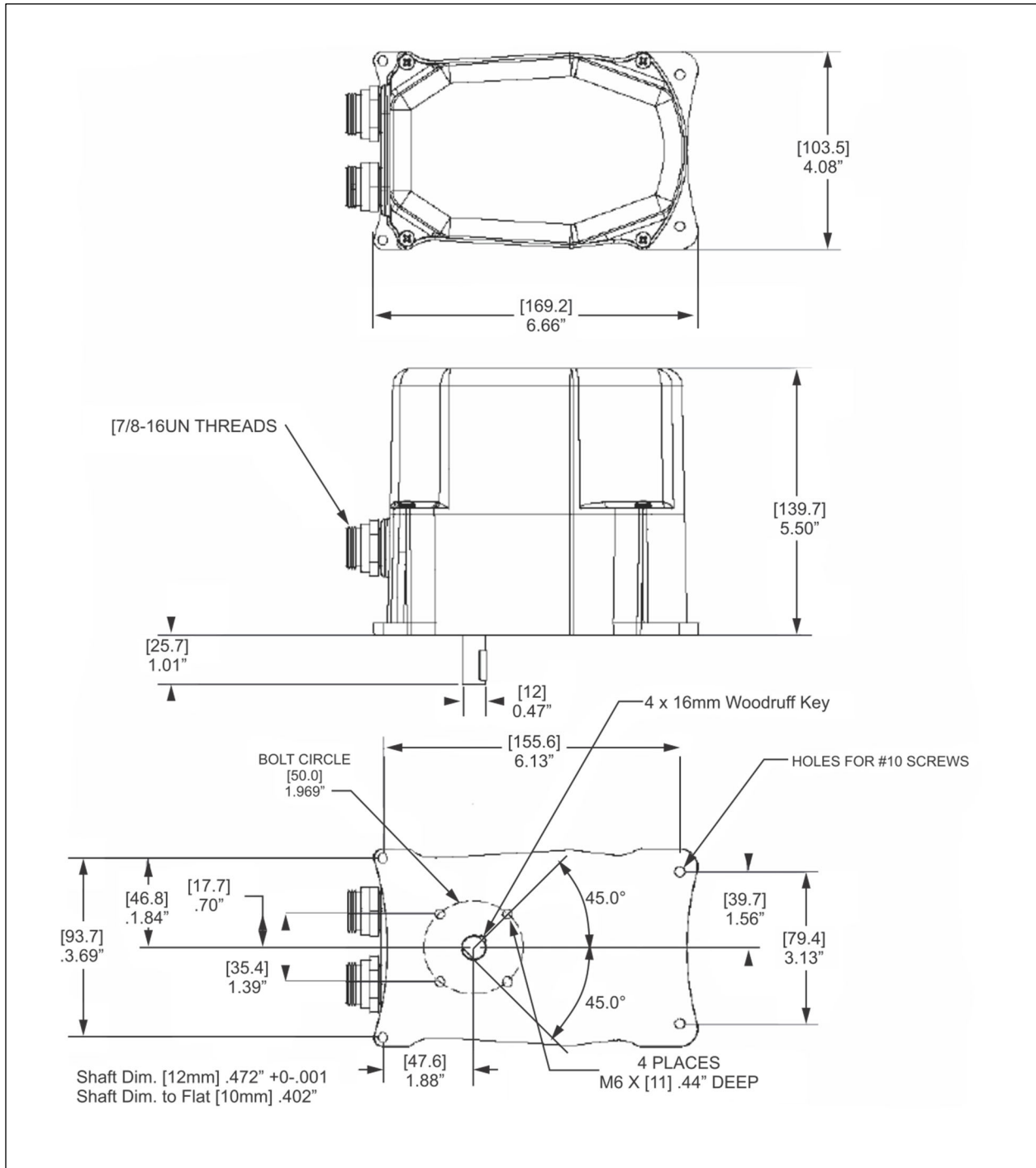



FX50 dimensions

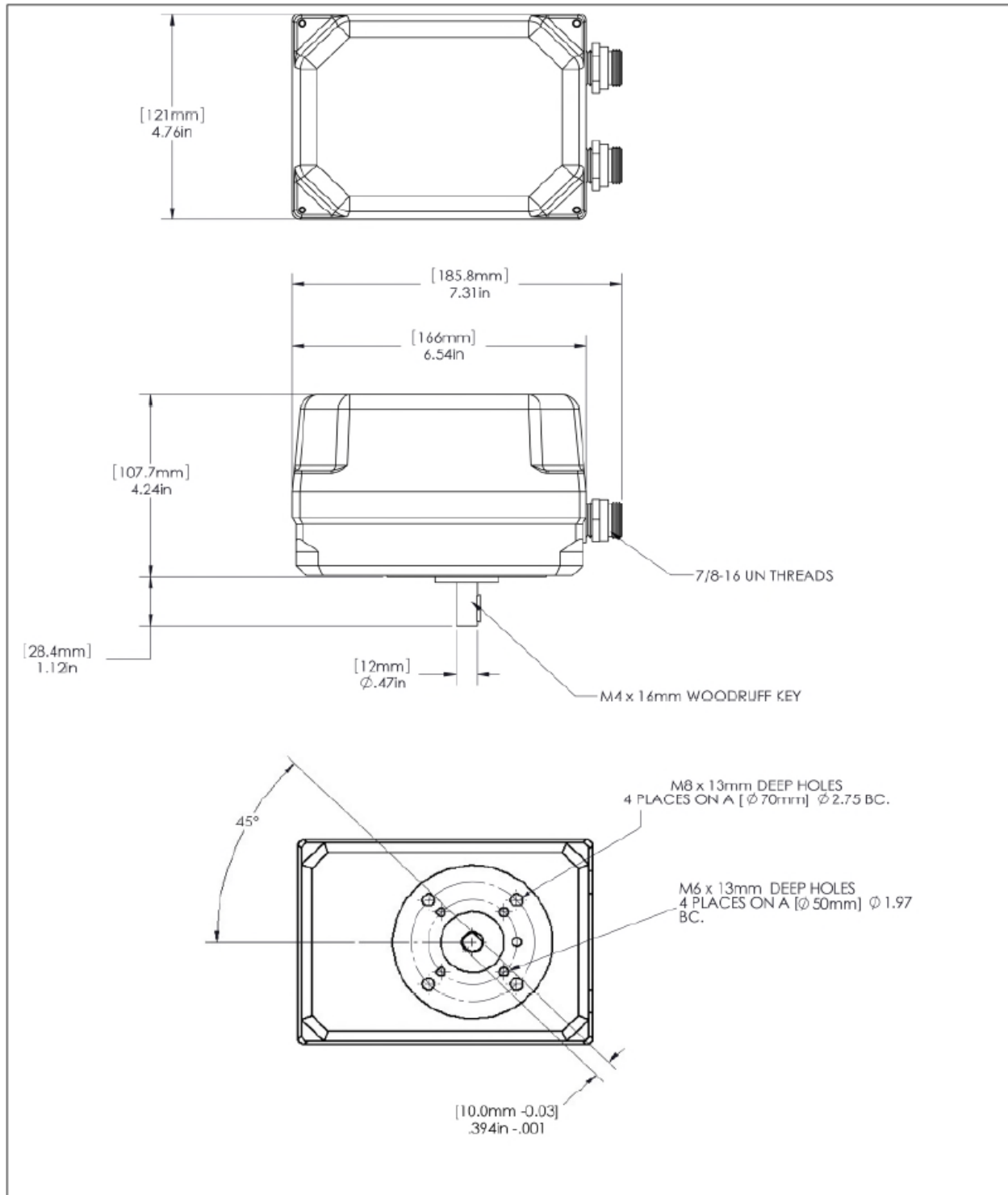



INSTALLATION



WARNING – All installation, service and troubleshooting of Fireeye products must be performed by a qualified technician!

Fasten the FX servo motor using bolts through a suitable mounting so that the mounting surface rests flat. The FX04 has four 5mm through-holes for mounting with nuts/bolts. The FX20 has four 6mm through-holes for mounting with nuts/bolts. The FX50 has two threaded options: (4) M6 x 13mm or (4) M8 x 13mm. For the FX50, both are in a square pattern around the shaft to allow locking the position by 90°.

The output drive shaft should be connected using a suitable arm, link, flexible coupling or D-hole couplings in order to assure a secure connection.

The FX series servo can be mounted in any orientation. Ensure that the installation has future service accessibility.

Class I Division 2 Hazardous Location requires that suitable wiring methods shall be used which meet the applicable requirements.

QUICK DISCONNECT CORD SETS

Cord sets having female connectors on both ends are available in 6 foot (59-565-6) and 40 foot (59-565-40) lengths.

Class I Division 2 Hazardous Location requirements for FX series servos with electrical connectors state that the coupling nut must be tightened after mating the cable to the servo.

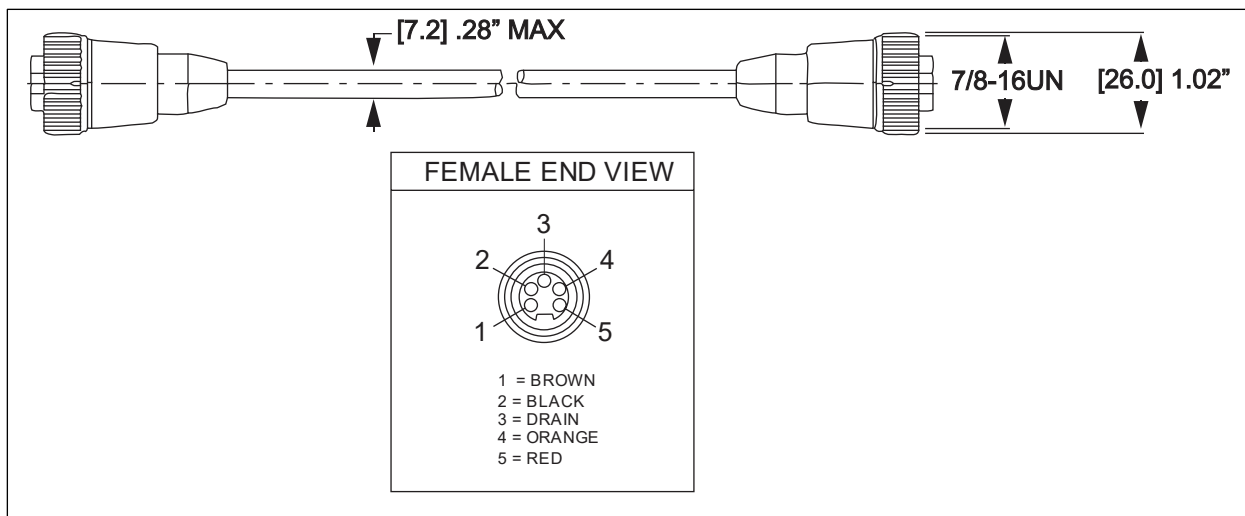



QUICK DISCONNECT FIELD WIRING

Quick disconnect connectors are available in kit form for field wiring, 129-192. Fireeye recommends cable part number 59-565 to be used for servo wiring.

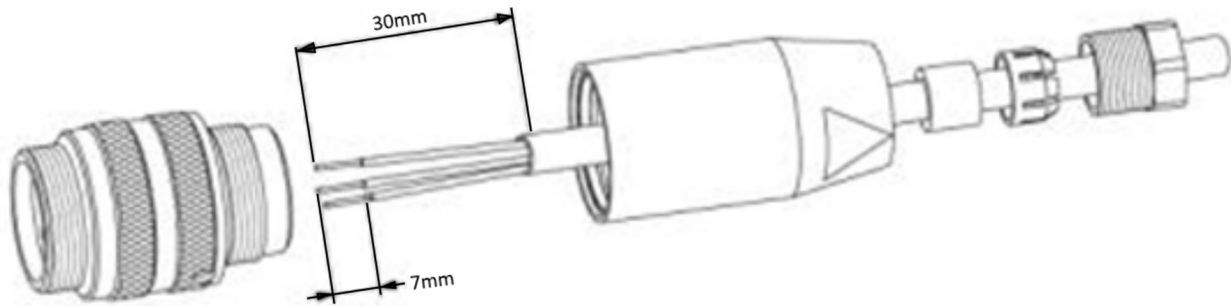

As shown above the cable strip length is specified at 30 mm (1.2 in) and each wire strip length is 7 mm (0.275 in).

To use cable 59-565, strip one end as specified. Strip each wire and wire to connector as shown in the image and table below:

Terminal designations

Terminal	Description	Color (59-565 cable)
1	Modbus B(-)	Brown
2	24VDC common	Black
3	Earth ground	Drain (bare)
4	Modbus A(+)	Orange
5	24VDC power	Red

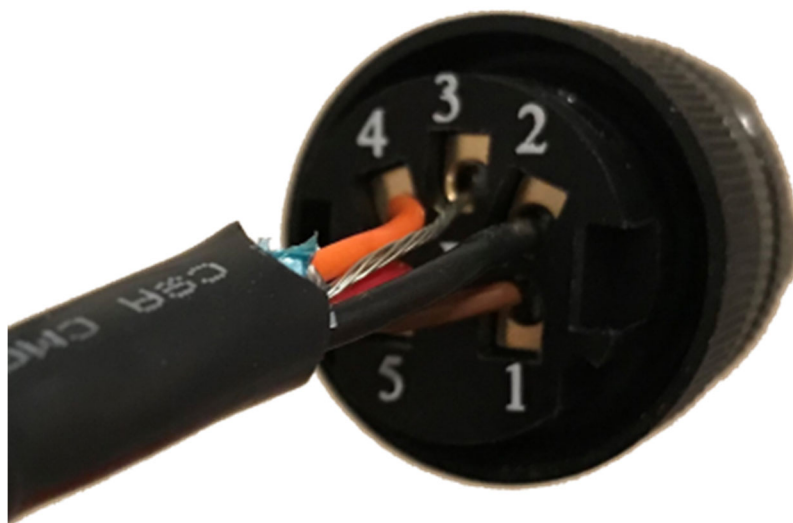



FIELD WIRING USING FIXED CABLE OR CONDUIT

Loosen the four housing cover screws and pull the cover up to remove. For the electrical installation of the FX series servo motor, use the prescribed cable type corresponding to the environmental conditions.

Feed cables through suitable conduit and place the stripped ends of the leads into screw connection terminals and terminate. Cable type 59-565 contains a drain wire, and care should be taken when routing this to terminal 3. Tubing should be placed over this bare wire. Wire ends should be properly stripped such that no bare wires protrude from the terminals and thus produce the risk of a current surge or a short circuit.

Store the cables such that they are not pinched when the housing cover is fitted. Also ensure that there is not any interfere with the internal end travel switch mechanism or potentiometer coupling shaft.

There are two terminals for each connection in the FX04 and FX20 to make it easier to wire the servos in a serial or daisy-chain as recommended by the RS-485 standard. The FX50 has larger terminals designed to accommodate two wires each.

Below is a table showing the descriptions of the terminals. For the 59-565 cable, the black and red wires are 18AWG and the brown and orange wires are a twisted pair.

Terminal designations

Terminal	Description	Color (59-565 cable)
1	Modbus B(-)	Brown
2	24VDC common	Black
3	Earth ground	Drain (bare)
4	Modbus A(+)	Orange
5	24VDC power	Red

FX04 terminal layout

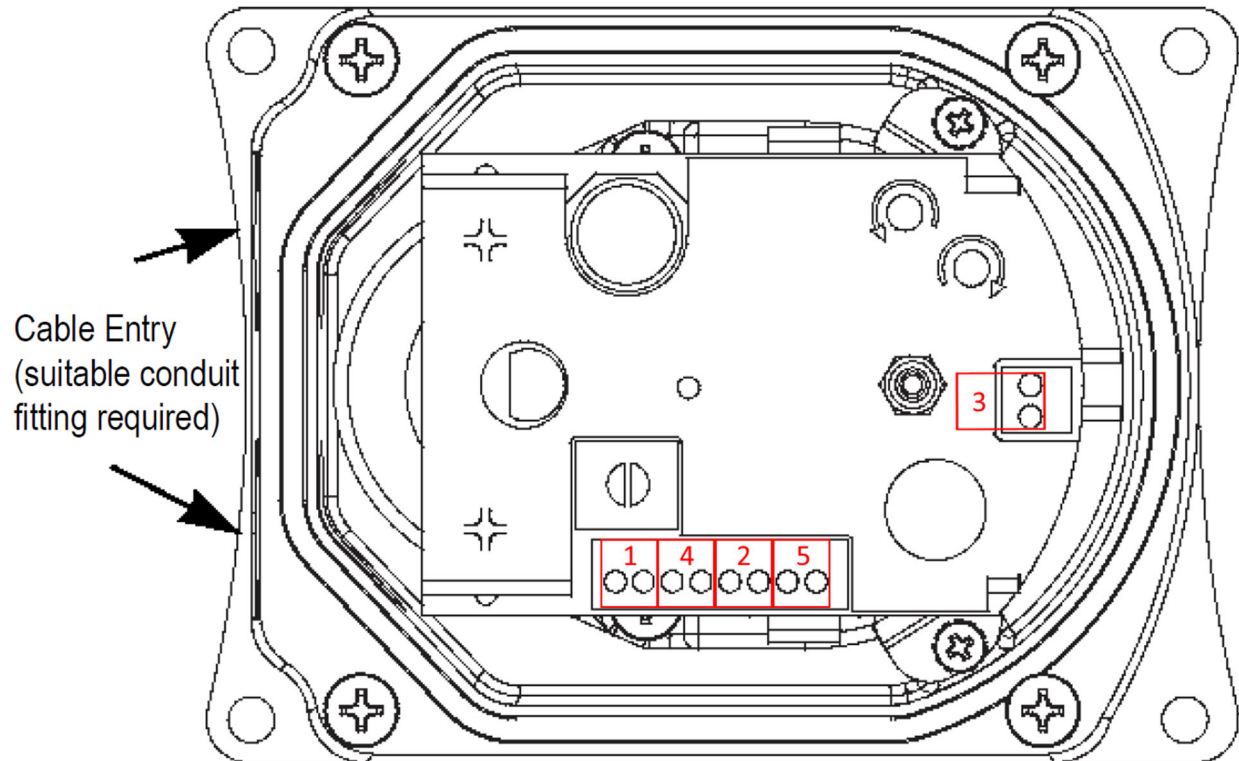

FX20 terminal layout

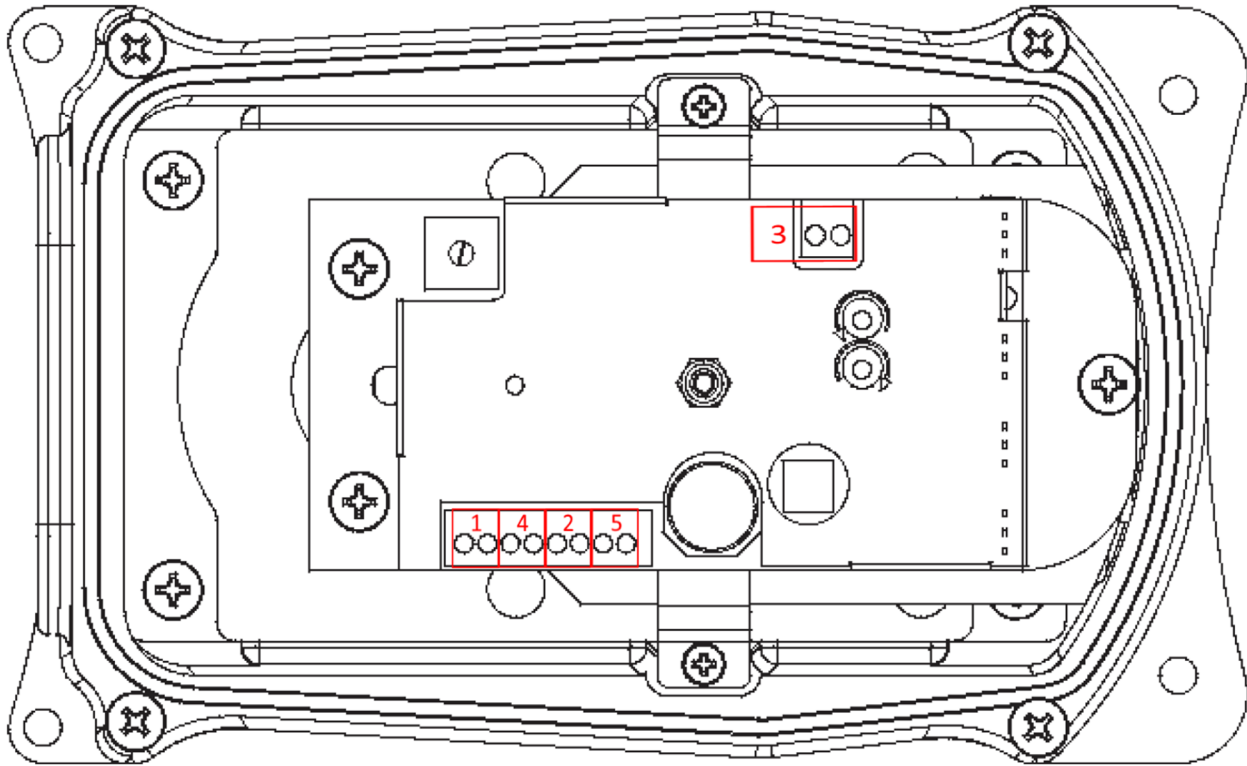



FX50 terminal layout

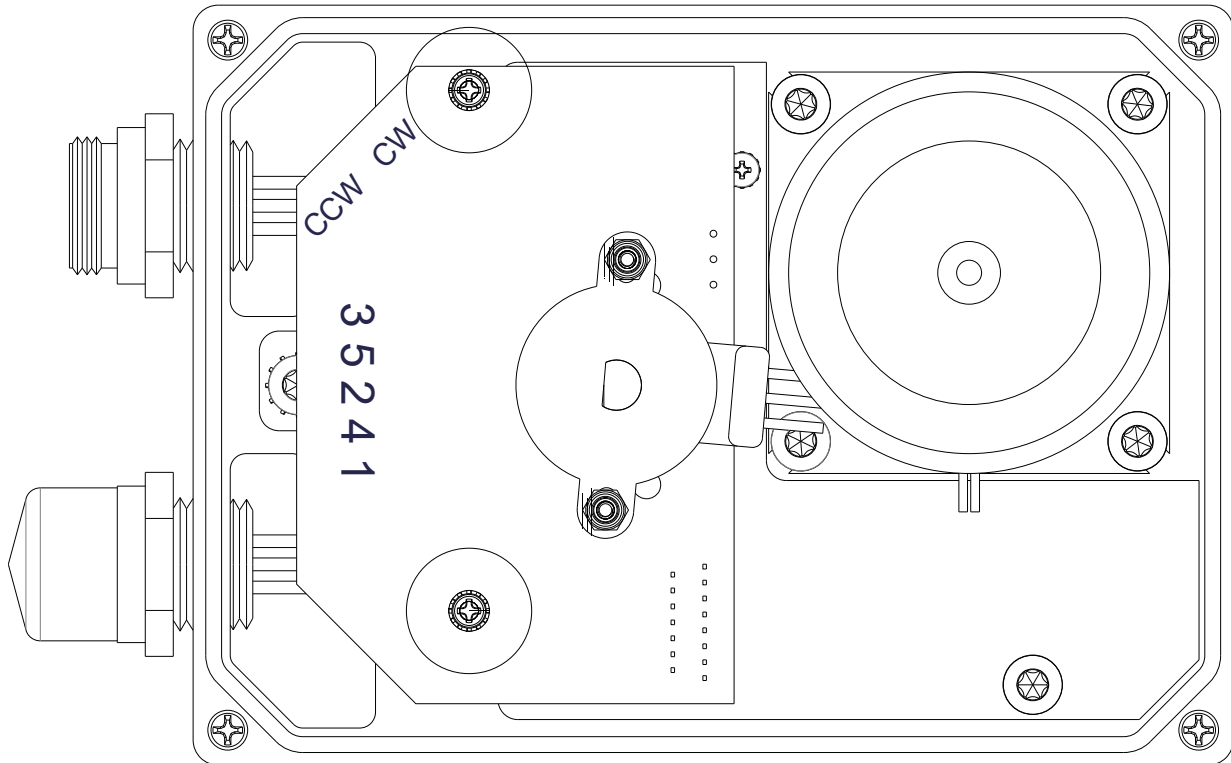

ADJUSTMENTS/COMMISSIONING

Adjustments

Before the servo motor is opened or commissioned, the Safety Information and Safety Advice sections must be read. The cover must be removed to make the following adjustments.

Unit address

The servos use the Modbus communication protocol via RS485. For the models FX04, FX04-1, FX20, FX20-1, FX50 and FX50-1, the baud rate is 56k. For most devices, a baud rate of 57.6k is within the tolerance of the internal UART and communication will be possible. For the models FX04-19, FX04-119, FX20-19, FX20-119, FX50-19 and FX50-119, the baud rate is 19.2k. For the models FX04-38, FX04-138 the baud rate is 38.4k. For all models, the format is fixed to eight data bits, no parity and one stop bit (8, N, 1).

Each servo connected must have its own unique unit address. Before applying power, use the rotary switch (location shown in Servo Motor Diagram section or on image below) to select the unit address. The address is selectable from 1 through 10 (10 is represented as 0 on the switch). If the unit address is changed, a power cycle is necessary since the address is only read from the switch at power-up.

Manual movement

The servo can be moved manually by using the two red buttons (location shown in Servo Motor Diagram section or on image below) whenever power is applied to the servo. There are separate buttons for CW and CCW movement. The servo will automatically stop when it reaches the end of available travel. Note that if Modbus commands are actively setting the position, the manual movement buttons will not override those commands – the position will immediately return to the commanded Modbus position. Pausing those Modbus commands will allow for manual movement.

Replace the servo cover after selecting the unit address and when finished making manual movements.

Cover off, showing location of address selection rotary switch and manual movement pushbuttons

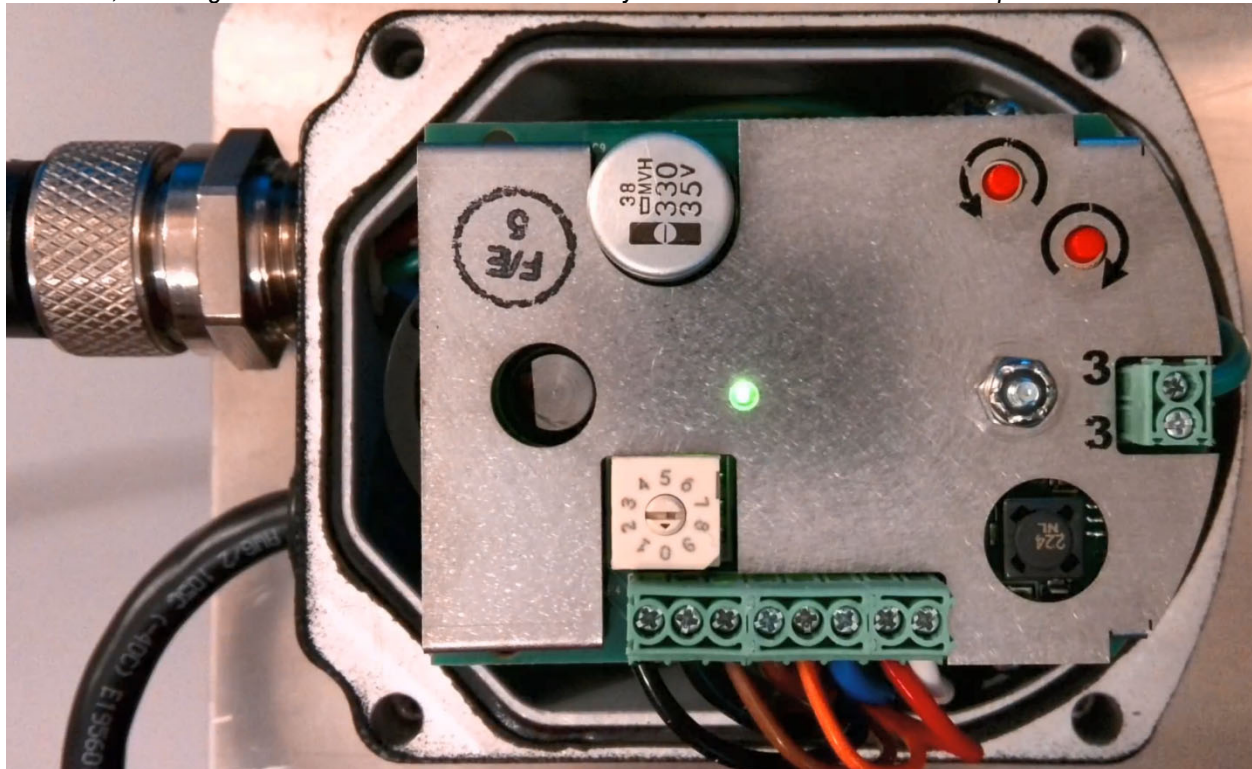



MODBUS CONTROL SPECIFICS

Read values

Use function code 03 (read 4x or holding registers) for reading Modbus data. When reading values, any register valid for the write operation can be selected as the starting address. The length is what determines how much information is presented. **Note that addresses shown begin at 0.**

Read registers

Starting address FX04	Starting address FX20	Starting address FX50	Register in sequence	Description of data	Range
any 1-30	any 1-61	any 1-60	1 st	Commanded position in angular degrees x10	3 to 1100 (65535 indicates error)
any 1-30	any 1-61	any 1-60	2 nd	Current servo position in angular degrees x10	3 to 1100
any 1-30	any 1-61	any 1-60	3 rd bits 0-7	Tweak mode error percent and rotation direction	-100 to 100 0 indicates no error CW: positive value CCW: negative value
any 1-30	any 1-61	any 1-60	3 rd bits 8-15	Current servo speed and rotation direction, higher value is faster <i>Note: The value corresponds to the write address used</i>	FX04: -30 to 30 FX20: -61 to 61 FX50: -60 to 60 0 indicates stationary CW: positive value CCW: negative value
any 1-30	any 1-61	any 1-60	4 th bits 0-5	Error code <i>Note: See Error Codes section</i>	0 to 14 0 indicates no error
any 1-30	any 1-61	any 1-60	4 th bit 6	CW or CCW button pressed	0 or 1
any 1-30	any 1-61	any 1-60	4 th bit 7	Tweak mode active	0 or 1
any 1-30	any 1-61	any 1-60	4 th bits 8-15	Servo torque rating in Nm	4, 20 or 50
any 1-30	any 1-61	any 1-60	5 th	Linearity error since last command in angular degrees x10	-100 to 100
any 1-30	any 1-61	any 1-60	6 th	Firmware revision	Read in hex

Tweak mode

Tweak mode is an internal process used for fine adjustment of the position when the servo is near the commanded position. The information is provided read-only – no adjustments are possible.

Linearity error

The linearity error is the difference between what the potentiometer is reading and how far the motor should have moved. An error is normal due to time lag as well as the inherent non-linearity of the potentiometer. This will normally be within one angular degree (value between -10 and 10). The information is provided read-only – no adjustments are possible.



Error codes

Sending a commanded position to the servo will erase/reset the present error code. It should be your normal process to read the servo before sending a new commanded position so that any detected errors will not be missed. In addition, once an error is detected, the servo will stop moving and release any braking feature. The servo will remain in an error state as long as power is not recycled or a commanded position is not sent.

Error codes

Error Code	Description	Possible Remedies
0	No error	
1-7	Internal CPU self-check error	Re-write the commanded position. Log when error occurred to determine frequency of error.
8	Servo shaft is not moving as expected	The shaft is jammed or the actuator is undersized for the application. Check linkage for binding or lubrication problems. The supply voltage is too low or the motor may be extremely hot.
9-10	Voltage regulator self-check error	Re-write the commanded position. Log when error occurred to determine frequency of error.
11	Under voltage – below 21.6VDC	Power cable is too long or gauge of wire is too small. Power supply may also not be able to handle the load. Measure power supply and/or monitor power supply voltage at actuator to determine where the problem lies.
12	Over voltage – above 33VDC	Measure the power supply voltage to ensure that voltage is not set too high. Inductive or capacitive coupling may cause spikes on supply line. Separate actuator power supply lines from other high power lines.
13-14	Internal current regulation faulty	Re-write the commanded position. Log when error occurred to determine frequency of error.

Write values

Use function code 06 (write single 4x or holding register) for writing Modbus data. Note that function code 16 (write multiple 4x or holding registers) will not work, even if the length is specified to be one address.

Note that addresses shown begin at 0.

The register written to determines the speed at which the servo will move. Writing to register 1 (40002) will move the servo at its slowest speed. Writing to register 2 (40003) will move the servo slightly faster. The higher the register number, the faster the servo will move up. The servo will move at the fastest speed (90 degrees in 30 seconds) at a different register for each model – see the write table in this section for a listing of all the registers and their corresponding speeds. Writing to a register higher than then model of servo supports will result in a Modbus exception to be returned to the Modbus controller. The number written to the register can range from 0 to 1100 representing the full range of the servo (110 degrees) in tenths of a degree. For example, writing a 450 to register 30 (40031) on an FX04 will cause the servo to go to the 45.0 degree position at the maximum speed. Note that while a position of 0 can be commanded, the lowest position that can be reached is 3 (0.3 angular degrees).

A new position or speed can be sent at any time. The user does not have to wait for the servo to reach the previous commanded position before issuing a new position.



Write registers

Register	Register (4x)	FX04 Travel Time in Seconds	FX20 Travel Time in Seconds	FX50 Travel Time in Seconds
1	40002	126	368.4	202.1
2	40003	114	310.1	172.1
3	40004	104	267.7	148.2
4	40005	95	235.6	130.1
5	40006	88	210.3	116.4
6	40007	81	189.9	105.8
7	40008	76	173.2	97.4
8	40009	71	159.1	90.6
9	40010	67	147.2	84.9
10	40011	63	136.9	80.1
11	40012	30	127.9	76.0
12	40013	57	120.1	72.4
13	40014	54	113.2	69.3
14	40015	52	107.0	66.5
15	40016	50	101.5	64.0
16	40017	48	96.5	61.7
17	40018	46	91.9	59.7
18	40019	44	87.8	57.8
19	40020	42	84.1	56.1
20	40021	41	80.6	54.6
21	40022	39	77.4	53.1
22	40023	38	74.5	51.8
23	40024	37	71.8	50.5
24	40025	36	69.2	49.4
25	40026	35	66.8	48.3
26	40027	34	64.6	47.2
27	40028	33	62.6	46.3
28	40029	32	60.6	45.4
29	40030	31	58.8	44.5
30	40031	30	57.1	43.7
31	40032	invalid	55.5	42.9
32	40033	invalid	54.0	42.2
33	40034	invalid	52.5	41.5
34	40035	invalid	51.2	40.8
35	40036	invalid	49.8	40.1
36	40037	invalid	48.6	39.5
37	40038	invalid	47.4	39.0
38	40039	invalid	46.3	38.4
39	40040	invalid	45.2	37.9
40	40041	invalid	44.2	37.3
41	40042	invalid	43.3	36.8
42	40043	invalid	42.3	36.4
43	40044	invalid	41.4	35.9
44	40045	invalid	40.6	35.5
45	40046	invalid	39.7	35.0
46	40047	invalid	38.9	34.6
47	40048	invalid	38.2	34.2



48	40049	invalid	37.5	33.8
49	40050	invalid	36.8	33.5
50	40051	invalid	36.1	33.1
51	40052	invalid	35.4	32.7
52	40053	invalid	34.8	32.4
53	40054	invalid	34.2	32.1
54	40055	invalid	33.6	31.8
55	40056	invalid	33.0	31.4
56	40057	invalid	32.5	31.1
57	40058	invalid	32.0	30.8
58	40059	invalid	31.5	30.6
59	40060	invalid	31.0	30.3
60	40061	invalid	30.5	30.0
61	40062	invalid	30.0	invalid

CERTIFICATIONS FX04, FX04-1, FX20, FX20-1, FX50 AND FX50-1

UL: MP1537 & MH10808

FM: FM 7610

ETL: ISA 12.12.01:2016 Ed.7, CSA C22.2#213:2016 Ed.2



Conforms to ISA 12.12.01:2016 Ed.7

Cert. to CAN/CSA Std. C22.2 No. 213:2016 Ed. 2

FX04, FX04-1:

CLASS I, DIVISION 2, GROUPS A, B, C AND D, HAZARDOUS LOCATIONS

TEMPERATURE CODE T5

AMBIENT TEMPERATURE RANGE -20°C TO +60°C

FX20, FX20-1:

CLASS I, DIVISION 2, GROUPS A, B, C AND D, HAZARDOUS LOCATIONS

TEMPERATURE CODE T5

AMBIENT TEMPERATURE RANGE -20°C TO +60°C

FX50, FX50-1:

CLASS I, DIVISION 2, GROUPS A, B, C AND D, HAZARDOUS LOCATIONS

TEMPERATURE CODE T4A

AMBIENT TEMPERATURE RANGE -20°C TO +60°C

CERTIFICATIONS FX04-19, FX04-119, FX04-38, FX04-138, FX20-19, FX20-119, FX50-19 AND FX50-119

UL: MH10808



NOTICE

When Fireeye products are combined with equipment manufactured by others and/or integrated into systems designed or manufactured by others, the Fireeye warranty, as stated in its General Terms and Conditions of Sale, pertains only to the Fireeye products and not to any other equipment or to the combined system or its overall performance.

WARRANTIES

FIREYE guarantees for one year from the date of installation or 18 months from date of manufacture of its products to replace or repair (Fireeye's option) any product or part thereof (except lamps and photocells) which is found defective in material or workmanship or which otherwise fails to conform to the description of the product on the face of its sales order. **THE FOREGOING IS IN LIEU OF ALL OTHER WARRANTIES AND FIREYE MAKES NO WARRANTY OF MERCHANTABILITY OR ANY OTHER WARRANTY, EXPRESS OR IMPLIED.** Except as specifically stated in these general terms and conditions of sale, remedies with respect to any product or part number manufactured or sold by Fireeye shall be limited exclusively to the right to replacement or repair as above provided. In no event shall Fireeye be liable for consequential or special damages of any nature that may arise in connection with such product or part.