

Type 1080 Declutchable Manual Actuator

The Type 1080 manual actuator is a Declutchable Actuator for manual operation of A41 double D shaft control valves that use a Type 1035/EI-O-Matic power actuator. As shown in figure 1, the Type 1080 manual actuator mounts directly on the Type 1035 actuator. It can be engaged to allow manual operation of the valve when the power actuator is not in use or disengaged to allow automatic operation of the valve by the power actuator.

Features

- **Direct Attachment to the Power Actuator**— Direct mounting to the actuator housing simplifies installation and eliminates the need for additional mounting parts.
- **Engage Manual Actuator At Any Point of Rotation**— A lever-operated eccentric bearing support on the input shaft allows engagement of the worm gear with the sector at any point of rotation.
- **Simplified Selection**— Each size of the Type 1080 corresponds to the capabilities of a size of the Type 1035. So you need only calculate the size of the Type 1035, when ordering both a Type 1035 and Type 1080 (see table 1).
- **Positive Operation**— The disengagement lever is held in both the engaged and disengaged positions by a spring-loaded pin, which must be released before the lever can be moved. This reduces the possibility of inadvertent or accidental operation. In addition, stop-pins at the fully engaged and fully disengaged positions provide positive limits for lever travel.



W9256

Figure 1. Type 1080 Manual Actuator Mounted on a Type 1035/EI-O-Matic Actuator

Note

Neither Emerson, Emerson Process Management, nor any of their affiliated entities assumes responsibility for the selection, use and maintenance of any product. Responsibility for the selection, use, and maintenance of any product remains with the purchaser and end-user.



1080 Manual Actuator

Specifications

Available Configurations

Direct acting; see Handwheel Rotation

Manual Actuator Sizes

See table 1

Power Actuator Compatibility

Compatible with all sizes of Type 1035 actuator; see table 1

Maximum Torque Output

See table 1, Wheel-Rim Force

Handwheel Rotation

Clockwise handwheel rotation closes valve (produces clockwise valve shaft rotation)

Construction Materials

Housing and Cover: Cast iron

Drive Sleeve/Gear (Sector): Low-carbon steel/bronze

Worm Gear: Heat-treated steel

Input Shaft and Eccentric: Low-carbon steel/bronze

Pin Detent: 300 Series stainless steel

Shaft Bearings: Bronze

Mounting Positions (see figure 2)

■ Standard mounting is with the input shaft perpendicular to the Type 1035 actuator piston travel, with the handwheel opposite the actuator supply connections; ■ optional mounting is with the handwheel on the same side as the Type 1035 actuator supply connections

Dimensions

See figure 3

Approximate Weight without Handwheel

Size AAA: 5.4 kg (12 lb)

Size AA: 10 kg (22 lb)

Size A: 14 kg (31 lb)

Size B: 22 kg (49 lb)

Size C: 34 kg (76 lb)

Size D: 52 kg (115 lb)

Size F: 68 kg (150 lb)

Handwheel Weight

8-inch: 2.0 kg (4.50 lb)

12-inch: 4.0 kg (6.75 lb)

16-inch: 6.8 kg (15.00 lb)

24-inch: 5.4 kg (12.00 lb)

30-inch: 6.8 kg (15.00 lb)

36-inch: 7.8 kg (17.25 lb)

Ordering Information

Each size of the Type 1080 corresponds to a specific size of Type 1035 as shown in table 1. The torque output of the 1080 actuator is matched to the capabilities of the 1035 power actuator.

The 1080 actuator can handle the Spring Return 1035 actuator torques as well as the Double Acting 1035 actuator, because the Double Acting torque at 100 psig is approximately equal to the sum of both

the Spring Return spring start torque and the Spring Return air end torque at 100 psig.

An optional bypass valve should be ordered for use on a 1035 actuator if you plan to engage the manual actuator while the power actuator has air pressure applied to it. For activation of the Type 1080, air pressure must not be trapped in the Type 1035 or must be equalized between the pistons by a bypass valve.

Product Bulletin

22.2:1080
February 2007

1080 Manual Actuator

Table 1. Actuator Size Selection and Specifications⁽¹⁾

ACTUATOR SIZE	TYPE 1035 ACTUATOR SIZE	GEAR RATIO	NUMBER OF TURNS TO CLOSE	HANDWHEEL DIAMETER		1080 MAXIMUM TORQUE ⁽²⁾		1035 TORQUE ⁽³⁾		WHEEL RIM FORCE FOR MAXIMUM TORQUE ⁽⁴⁾	
				mm	Inches	N•m	lb•in	N•m	lb•in	N	lbf
AAA/S1	E25	24:1	6	203	8	271	2,400	31	274	49	11
AAA/S2	E40							58	513	93	21
	E65							89	788	147	33
AAA/S3	E100							132	1,168	218	49
AA/S4	E200	34:1	8.5	305	12	542	4,800	289	2,558	222	50
	E350							502	4,443	387	87
A/S4	E600	32:1	8	610	24	926	8,200	866	7,550	276	62
B/S5	E950	40:1	10			1,356	12,000	1,290	11,300	271	61
C/S6	E1600	54:1	13.5	762	30	2,034	18,000	2,140	18,600	298	67
D/SQ3	P2500	64:1	16	914	36	3,390	30,000	3,377	29,891	383	86
F/SQ4	P4000	282:1	70.5	406	16	6,779	60,000	5,701	50,458	334	75

1. Only the 1080/1035 combinations shown are available.
2. Maximum torque output of the 1080 actuator only.
3. Torque output of the 1035 actuator at 100 psig and required 1080 torque output for use with the 1035.
4. Amount of force necessary at rim of the handwheel to match torque output of the 1035 at 100 psig.

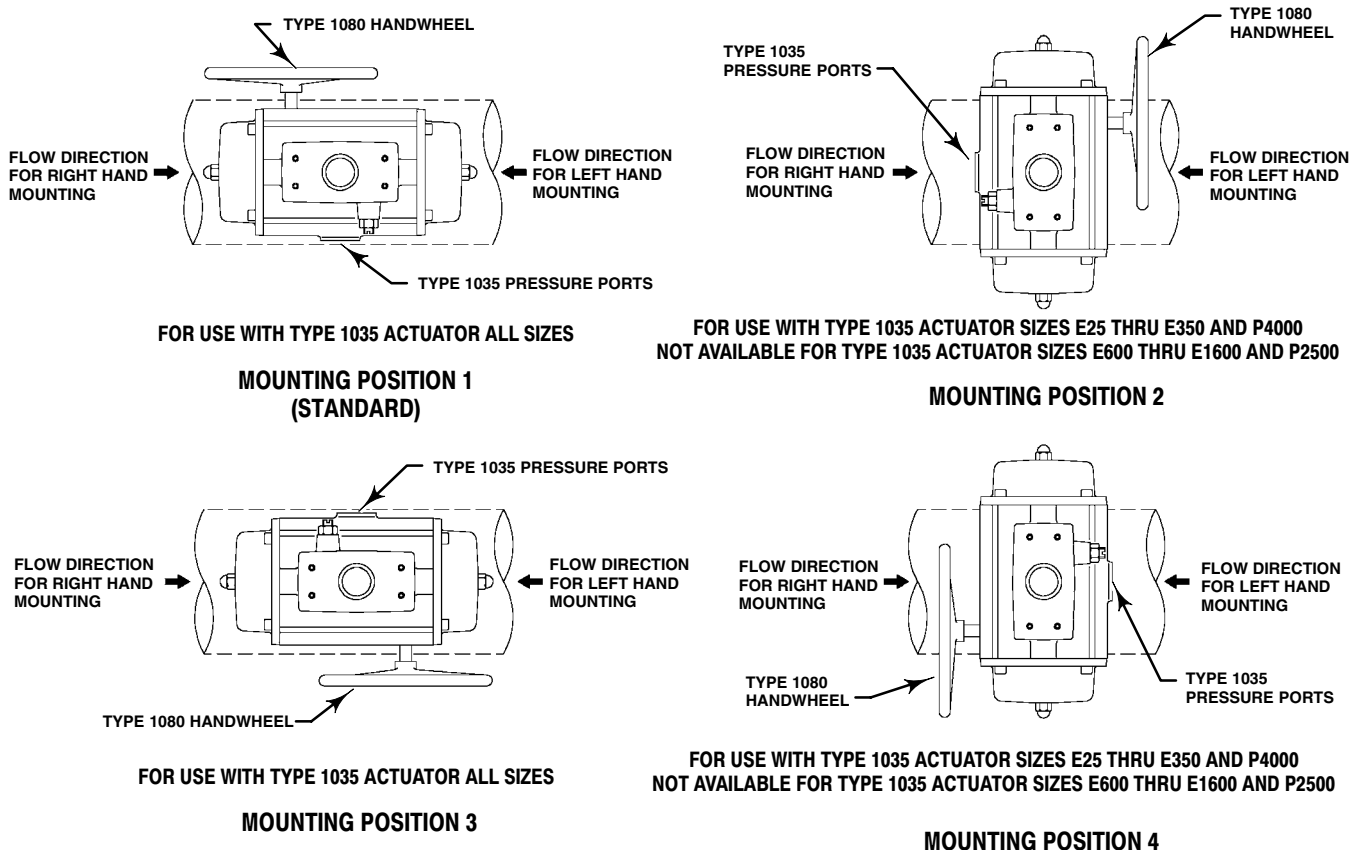

NOTE:
RIGHT AND LEFT HAND MOUNTING IS BASED ON THE TYPE A41 VALVE DRIVE SHAFT BEING MOUNTED IN THE RECOMMENDED HORIZONTAL POSITION.

75B0768
B2702 / IL

Figure 2. Type 1080 Actuator Mounting Positions

1080 Manual Actuator

Table 2. Dimensions

Type 1080 Actuator Size	Type 1035 Actuator Size	JØ	HW	M	D	DW	EW	FD	GE	NE	ND	KW Bolt Circle Diameter
mm												
AAA/S1	E25	203	191	68	30	73	132	153	55	46	51	50
AAA/S2	E40 E65	203	191	68	30	73	132	153	55	46	51	70
AAA/S3	E100	203	191	68	30	73	132	153	55	46	51	70
AA/S4	E200 E350	305	210	89	29	83	181	216	94	59	64	102
A/S4	E600	610	381	105	32	89	337	378	238	67	73	125
B/S5	E950	610	381	114	41	105	346	394	222	83	89	140
C/S6	E1600	762	406	143	44	117	425	492	276	105	111	165
D/SQ3	P2500	914	427	171	67	168	524	583	338	119	125	165
F/SQ4	P4000	406	451	171	162	168	365	441	178	127	137	165
Inches												
AAA/S1	E25	8	7.50	2.69	1.188	2.88	5.19	6.03	2.18	1.83	2.03	1.969
AAA/S2	E40 E65	8	7.50	2.69	1.188	2.88	5.19	6.03	2.18	1.83	2.03	2.756
AAA/S3	E100	8	7.50	2.69	1.188	2.88	5.19	6.03	2.18	1.83	2.03	2.756
AA/S4	E200 E350	12	8.25	3.50	1.126	3.25	7.13	8.50	3.69	2.31	2.50	4.016
A/S4	E600	24	15.00	4.13	1.253	3.50	13.25	14.88	9.38	2.63	2.88	4.921
B/S5	E950	24	15.00	4.50	1.625	4.12	13.62	15.50	8.75	3.25	3.50	5.512
C/S6	E1600	30	16.00	5.62	1.750	4.62	16.75	19.38	10.88	4.12	4.38	6.496
D/SQ3	P2500	36	16.81	6.75	2.630	6.63	20.63	22.94	13.31	4.69	4.94	6.496
F/SQ4	P4000	16	17.75	6.75	6.380	6.63	14.38	17.38	7.00	5.00	5.38	6.496

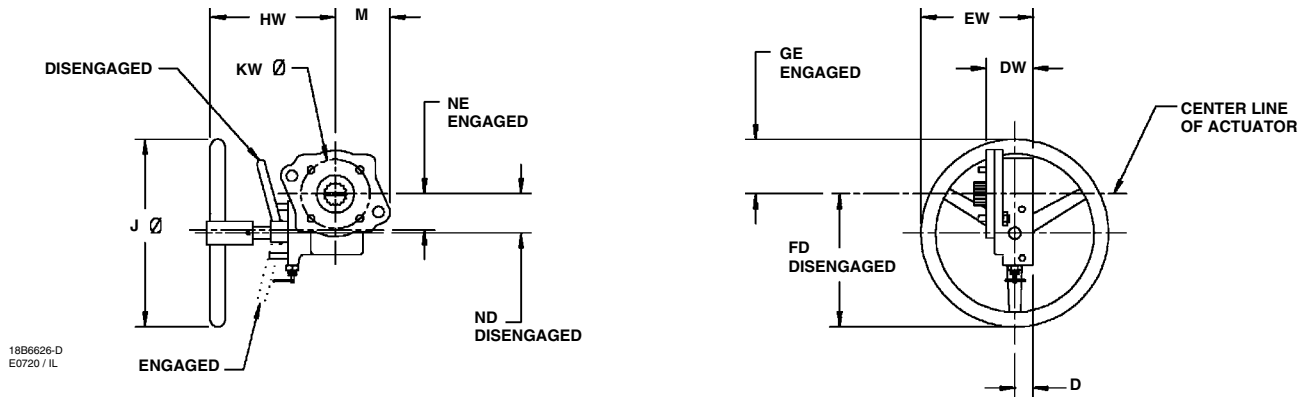

Figure 3. Dimensions (also see table 2)

Fisher is a mark owned by Fisher Controls International LLC, a member of the Emerson Process Management business division of Emerson Electric Co. Emerson Process Management, Emerson, and the Emerson logo are trademarks and service marks of Emerson Electric Co. All other marks are the property of their respective owners.

The contents of this publication are presented for informational purposes only, and while every effort has been made to ensure their accuracy, they are not to be construed as warranties or guarantees, express or implied, regarding the products or services described herein or their use or applicability. We reserve the right to modify or improve the designs or specifications of such products at any time without notice.

Neither Emerson, Emerson Process Management, nor any of their affiliated entities assumes responsibility for the selection, use and maintenance of any product. Responsibility for the selection, use and maintenance of any product remains with the purchaser and end-user.

Emerson Process Management

Marshalltown, Iowa 50158 USA
 Cernay 68700 France
 Sao Paulo 05424 Brazil
 Singapore 128461

www.Fisher.com

