

## Quick Reference Guide

P/N 3300994, Rev. C

April 2003

# Model 3500 Transmitter (9-wire) or Model 3300 Peripheral Installation Instructions for Panel-Mount

For online technical support, use the EXPERT<sub>2</sub><sup>™</sup> system at [www.expert2.com](http://www.expert2.com). To speak to a customer service representative, call the support center nearest you:

- In the U.S.A., phone 1-800-522-MASS (1-800-522-6277)
- In Canada and Latin America, phone (303) 530-8400
- In Asia, phone (65) 6770-8155
- In the U.K., phone 0800 - 966 180 (toll-free)
- Outside the U.K., phone +31 (0) 318 495 67



## BEFORE YOU BEGIN

This quick reference guide explains basic installation guidelines for mounting the Micro Motion® Model 3300/3500 applications platform in a panel cutout.

For information on I.S. applications, refer to Micro Motion ATEX, UL, or CSA installation instructions.

For complete instructions about configuration, maintenance, and service, refer to the instruction manual shipped with the transmitter.

### **WARNING**

**Improper installation in a hazardous area can cause an explosion.**

For information about hazardous applications, refer to Micro Motion ATEX, UL, or CSA installation instructions, shipped with the transmitter or available from the Micro Motion web site.

### **WARNING**

**Hazardous voltage can cause severe injury or death.**

Install transmitter and complete all wiring before supplying power.

### **CAUTION**

**Improper installation could cause measurement error or flowmeter failure.**

Follow all instructions to ensure transmitter will operate correctly.

## European installations

This Micro Motion product complies with all applicable European directives when properly installed in accordance with the instructions in this quick reference guide. Refer to the EC declaration of conformity for directives that apply to this product.

The EC declaration of conformity, with all applicable European directives, and the complete *ATEX Installation Drawings and Instructions* are available on the internet at [www.micromotion.com/atex](http://www.micromotion.com/atex) or through your local Micro Motion support center.

## Installation kit

The installation kit includes a bezel, frame, two mounting brackets with screws, a power supply wiring connector, and a retaining clip assembly for power supply wiring (see Figure 1).

The applications platform fits through a 5 7/16-inch (138 mm) square cutout in a panel that is 5/64 inch (2 mm) to 1/2 inch (13 mm) thick. The bezel provides a IP65 watertight seal between the panel cutout and the applications platform housing.

In addition, the installation kit includes:

- A bracketed wiring connector for screw-type connectors (see Figure 5, page 5), or
- I/O cables and connectors (see Figure 7, page 7)

**Figure 1. Panel-mount installation kit**

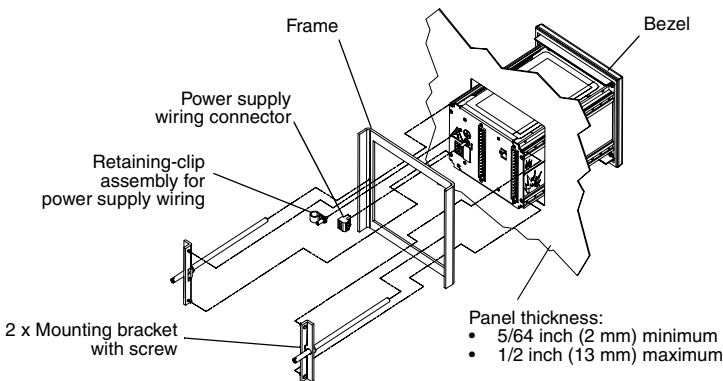

## STEP 1. Choosing a location

Choose a location for the transmitter based on the requirements described below.

### Environmental requirements

Install the transmitter where ambient temperature is between  $-4$  and  $+140$  °F ( $-20$  and  $+60$  °C).

### Dimensions

If the Model 3300/3500 has screw-type wiring connectors, see Figure 2 for dimensions. If the Model 3300/3500 has I/O cables, see Figure 3, page 4, for dimensions. (See Figures 5 and 7, pages 5 and 7, for illustrations of screw-type connectors versus I/O cables.)

**Figure 2. Panel-mount dimensions – screw-type connectors**

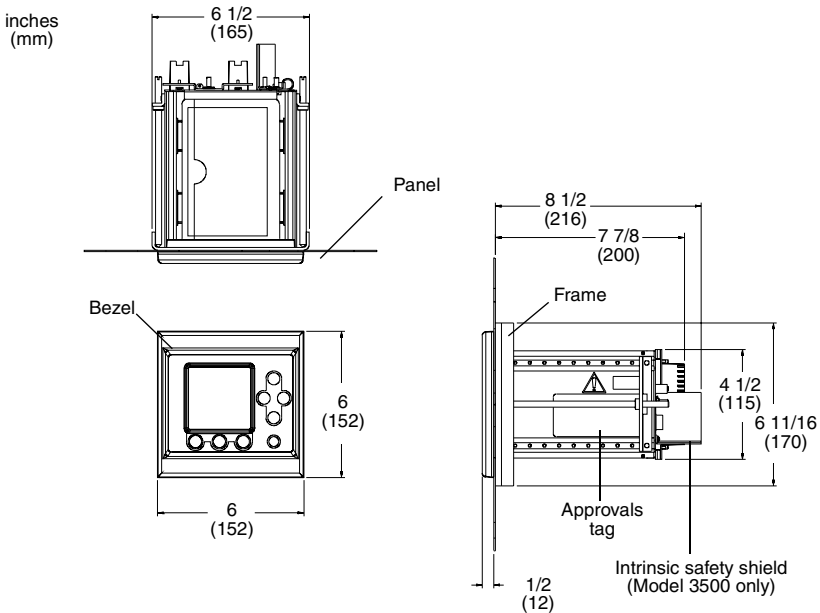

**Figure 3. Panel-mount dimensions – I/O cables**

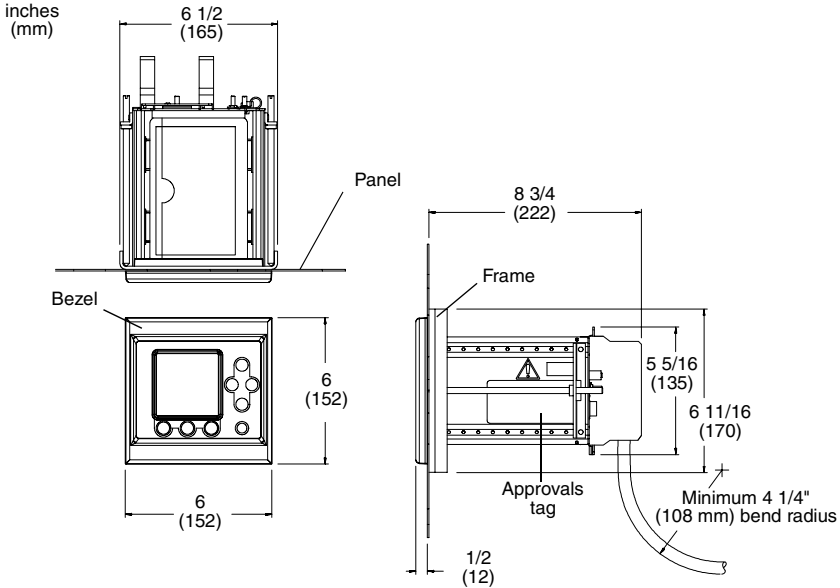

### **Flowmeter cable lengths**

Maximum cable length from the sensor to the Model 3500 transmitter is 1000 feet (300 meters).

If you are installing the Model 3300 applications peripheral in combination with a transmitter, the maximum cable length from the transmitter's frequency output to the Model 3300's frequency input is 500 feet (150 meters).

### **STEP 2. Installing the Model 3300/3500 in the panel**

Refer to Figure 4, page 5, and follow these steps:

1. Insert the Model 3300/3500 through the cutout.
2. Slide the frame over the housing.
3. Insert the posts on the brackets into the rails on the housing.
4. Tighten the screws evenly to 10 to 14 inch-pounds (1,13 to 1,38 Nm) to ensure a watertight seal between the gasket and the panel.

**Figure 4. Steps for installation in panel**

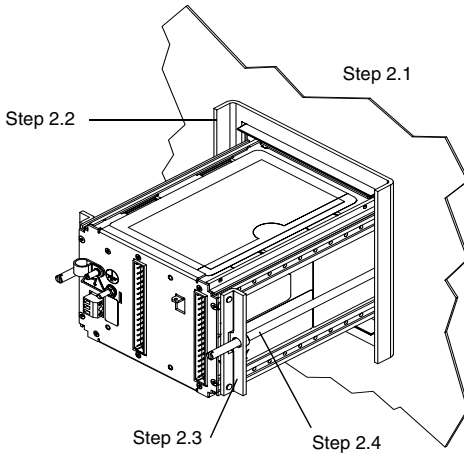

**STEP 3. Connecting input and output wiring**

If the Model 3300/3500 has screw-type connectors:

1. Plug the bracketed wiring connectors onto the terminal strips on the back panel of the Model 3300/3500 (see Figure 5). Tighten the captive screws to secure the bracket to the back panel.

**Figure 5. Wiring connectors and terminals – screw-type connectors**

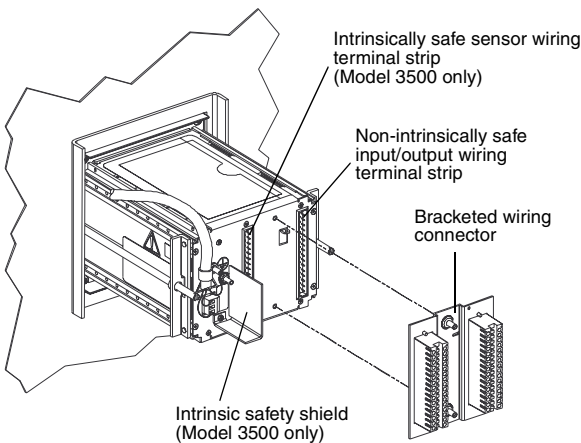



**Figure 7. Wiring connectors and terminals – I/O cables**

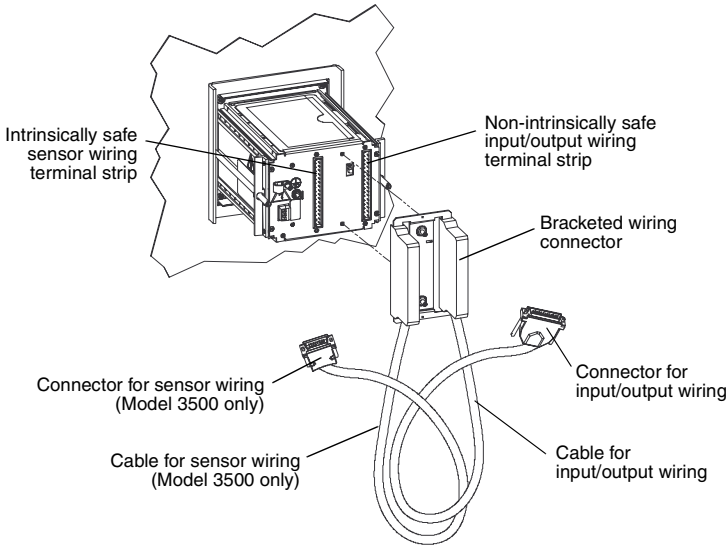

2. Attach the supplied I/O terminal block to a DIN rail. The terminal block fits various rail types. See Figure 8, page 8.
3. Plug the connector for input/output wiring onto the I/O terminal block. Tighten the captive screws to secure the connector to the I/O terminal block.
4. Connect input and output wiring to the appropriate terminals on the I/O terminal block. Refer to the label attached to the terminal block (shown in Figure 9, page 8), and Table 2, page 8.
  - Use 24 to 16 AWG (0,25 to 1,5 mm<sup>2</sup>) twisted-pair shielded wire.
  - Ground the shields at a single point only.

The I/O terminal block ground is available for continuation of user cable shielding to I/O cable shielding. The cable connector does not connect the I/O cable shielding to the chassis ground.

**Figure 8. Installing terminal block for I/O wiring on DIN rail**

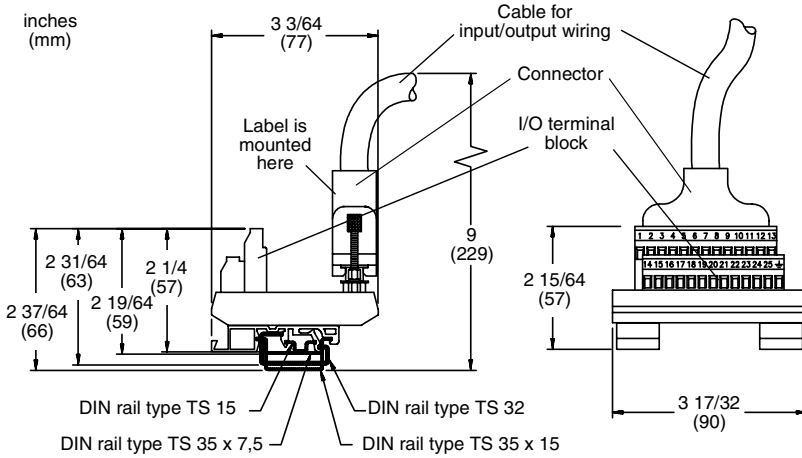

**Table 2. Input/output wiring terminals – I/O cables**

Terminal number		Designation
1 +	2 –	Secondary 4–20 mA output
14 +	15 –	Primary 4–20 mA output
3 +	4 –	Frequency input
5 +	6 –	Discrete input 1
7 +	8 –	Discrete input 2
16 +	17 –	Frequency output
18 +	19 –	Discrete output 1
20 +	21 –	Discrete output 2
22 +	23 –	Discrete output 3
24 (B line)	25 (A line)	RS-485 output

**Figure 9. Input/output wiring terminal card – I/O cables**

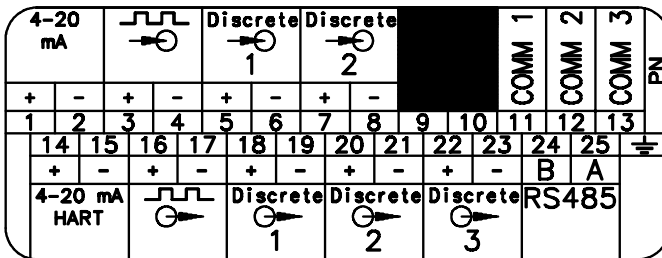

## STEP 4. Connecting the Model 3500 to the sensor

To connect the Model 3500 transmitter to a Micro Motion sensor, follow the steps below. If you are installing the Model 3300 applications peripheral, this step is not required.

Sensor wiring depends on the connectors supplied with the Model 3500:

- Screw-type connectors
- I/O cables

Follow the steps below to connect the Model 3500 to the sensor.

1. Identify the components:

- See Figure 10 for transmitters with screw-type connectors.
- See Figure 11, page 10, for transmitters with I/O cables.

**Figure 10. Sensor cable to Model 3500 – screw-type connectors**

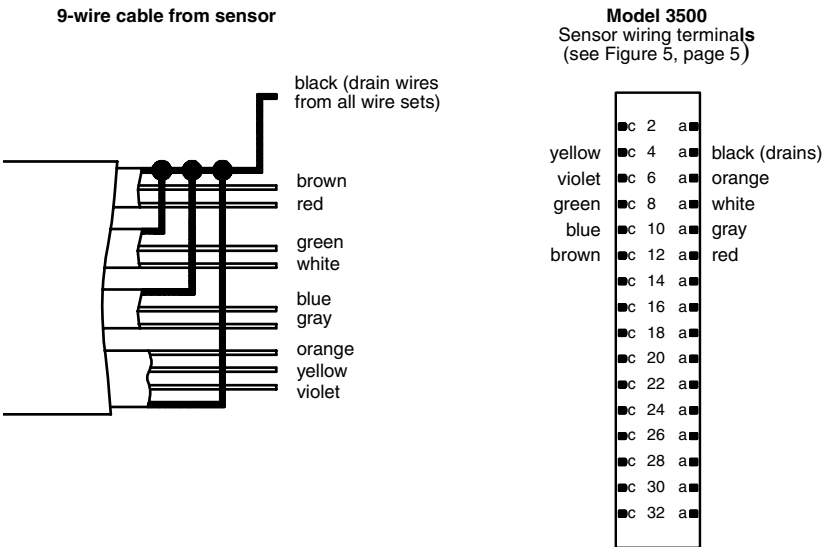

**Figure 11. Sensor cable to Model 3500 – I/O cables**

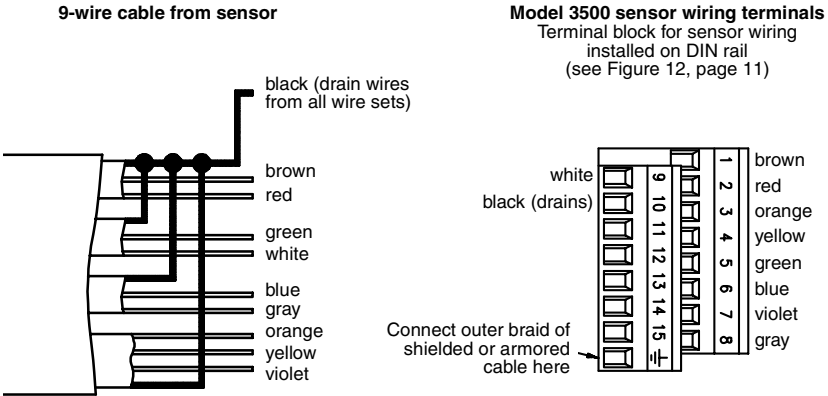

2. Prepare the cable according to the instructions in Micro Motion’s *9-Wire Flowmeter Cable Preparation and Installation Guide*.
3. Ensure that the cable has 360° shielding, continuous from the transmitter to the sensor’s junction box. Two methods can be used:
  - Metallic conduit
  - Shielded or armored cable

Refer to Micro Motion’s *9-Wire Flowmeter Cable Preparation and Installation Guide* for specific instructions.

4. At the sensor:
  - a. Clip the cable drain wires.
  - b. Connect wiring inside the junction box housing and tighten the screws to hold the wires in place.

For information on your sensor’s junction box terminals, see the sensor installation manual or Micro Motion’s *9-Wire Flowmeter Cable Preparation and Installation Guide*.

5. At the transmitter:

- For transmitters with screw-type connectors:
  - a. Connect the color-coded wires to the appropriate terminals. To identify the terminals, refer to Figure 10, page 9. No bare wires should remain exposed.
  - b. If using shielded or armored cable, connect the cable braid to the rear stud, as described in Micro Motion's *9-Wire Flowmeter Cable Preparation and Installation Guide*.
- For transmitters with I/O cables:
  - a. Attach the supplied terminal block for sensor wiring to a DIN rail. The terminal block fits various rail types (see Figure 12).
  - b. Plug the connector for sensor wiring onto the terminal block. Tighten the captive screws to secure the connector to the terminal block.
  - c. Connect the color-coded wires to the appropriate terminals on the terminal block. To identify the terminals, refer to Figure 11, page 10. No bare wires should remain exposed.
  - d. If using shielded or armored cable, connect the cable braid to the terminal as shown in Figure 11, page 10.

**Figure 12. Installing terminal block for sensor wiring on DIN rail**

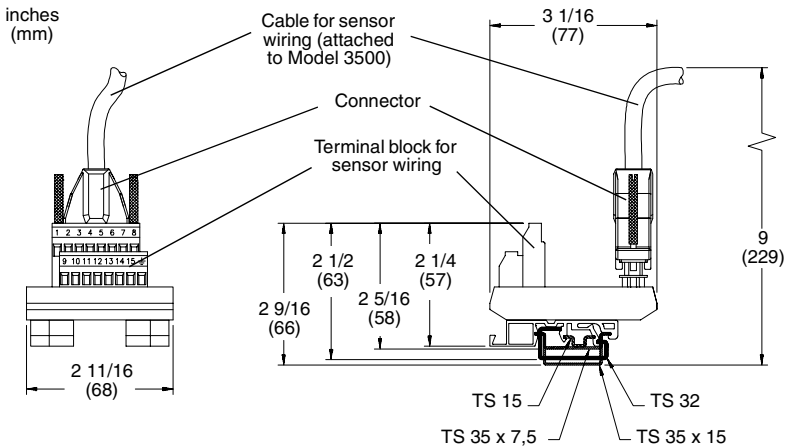

## STEP 5. Connecting power supply wiring

### CAUTION

**Improper wiring installation can cause device failure or measurement error.**

- To avoid device failure or measurement error, do not install power supply wiring in the same cable tray or conduit as input/output wiring.
- Shut off power supply before installing the applications platform.
- Make sure power supply voltage matches voltage that is indicated on power supply wiring terminals. See Figure 13, page 13.

Connect the Model 3300/3500 to a power supply as follows:

1. Plug in the power supply wiring connector. See Figure 13, page 13.
2. Connect 18 to 14 AWG (0,75 to 2,5 mm<sup>2</sup>) wiring to the power supply wiring connector.
3. Ground the power supply wiring:
  - Connect the ground wire to the ground lug for the power supply.
  - Connect the power supply ground directly to earth ground.
  - Keep all ground leads as short as possible.
  - Ensure that all ground wiring has less than 1 ohm impedance.
4. Connect wires to the power supply wiring terminals as shown in Figure 13, page 13.
5. Slide the retaining clip over the wiring, then tighten the screw to hold the clip in place. See Figure 1, page 2.

A user-supplied switch may be installed in the power supply line. For compliance with low-voltage directive 73/23/EEC (European installations), a switch in close proximity to the Model 3300/3500 is required.

**Figure 13. Power supply wiring terminals**

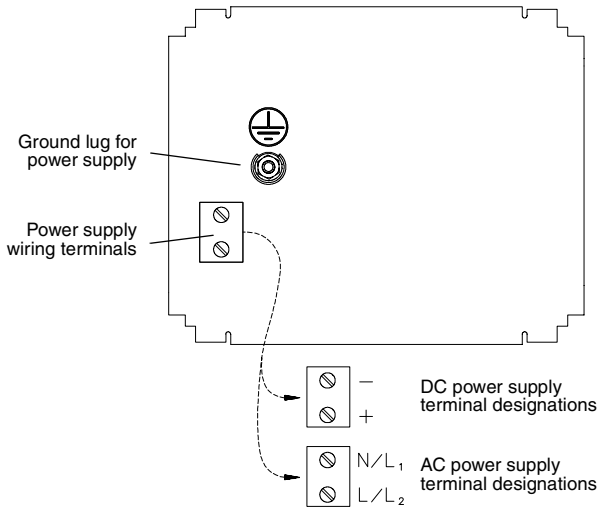



©2003. Micro Motion, Inc. All rights reserved. P/N 3300994, Rev. C



Visit us on the Internet at [www.micromotion.com](http://www.micromotion.com)

**Micro Motion Inc. USA**  
Worldwide Headquarters

7070 Winchester Circle  
Boulder, Colorado 80301  
T (303) 530-8400  
(800) 522-6277  
F (303) 530-8459

**Micro Motion Europe**

Emerson Process Management  
Wiltonstraat 30  
3905 KW Veenendaal  
The Netherlands  
T +31 (0) 318 495 670  
F +31 (0) 318 495 689

**Micro Motion Asia**

Emerson Process Management  
1 Pandan Crescent  
Singapore 128461  
Republic of Singapore  
T (65) 6777-8211  
F (65) 6770-8003

**Micro Motion United Kingdom**

Emerson Process Management Limited  
Horsfield Way  
Bredbury Industrial Estate  
Stockport SK6 2SU U.K.  
T 0800 966 180  
F 0800 966 181

**Micro Motion Japan**

Emerson Process Management  
Shinagawa NF Bldg. 5F  
1-2-5, Higashi Shinagawa  
Shinagawa-ku  
Tokyo 140-0002 Japan  
T (81) 3 5769-6803  
F (81) 3 5769-6843

